

DEPARTMENT OF THE ARMY

OPERATOR AND
ORGANIZATIONAL MAINTENANCE MANUAL
INCLUDING
REPAIR PARTS AND SPECIAL TOOL LISTS

LAUNCHER, ROCKET, 3.5-INCH M20A1 W/E
(1055-840-1841)
AND
LAUNCHER, ROCKET, 3.5-INCH M20A1 B1 W/E
(1055-840-1842)

This copy is a reprint which includes
current pages from Change 1.

HEADQUARTERS, DEPARTMENT OF THE ARMY
October 1968

TECHNICAL MANUAL }
No. 9-1055-201-12 }

HEADQUARTERS
DEPARTMENT OF THE ARMY
WASHINGTON, D.C., 9 October 1968

**OPERATOR AND ORGANIZATIONAL
MAINTENANCE MANUAL
INCLUDING REPAIR PARTS AND
SPECIAL TOOL LISTS
FOR
LAUNCHER, ROCKET, 3.5-INCH M20A1 W/E
(1055-840-1841) AND LAUNCHER, ROCKET,
3.5-INCH M20A1 BI
W/E (1055-840-1842)**

This manual is current as of 1 June 1968.

CHAPTER		INTRODUCTION	Paragraph	Page
Section	I.	General-----	1-1, 1-2	3
	II.	Description and data -----	1-3, 1-6	3, 8
CHAPTER	2.	OPERATING INSTRUCTIONS		
Section	I.	Services upon receipt of materiel -----	2-1, 2-2	9
	II.	Controls. -----	2-3	10
	III.	Operation under usual conditions-----	2-4, 2-13	12, 21
	IV.	Operation under unusual conditions ----	2-14, 2-16	21, 22
CHAPTER	3.	OPERATOR AND ORGANIZATIONAL MAINTENANCE INSTRUCTIONS		
Section	I.	Tools and equipment and repair parts--	3-1, 3-2	24
	II.	Cleaning and lubrication instructions ---	3-3, 3-4	24
	III.	Preventive maintenance checks and services-----	3-5, 3-6	27
	IV.	Troubleshooting-----	3-7	30
	V.	Maintenance procedures-----	3-8, 3-11	32

*This manual supersedes TM 9-1055-201-12P, in its entirety, 5 December 1962 including changes and that portion pertaining to Operator and Organizational maintenance of TM 9-1055-201-14, 13 May 1964 including changes.

		Paragraph	Page
CHAPTER	4. AMMUNITION-----	4-1, 4-9	33, 50
	5. DEMOLITION OF MATERIEL TO PREVENT ENEMY USE-----	5-1, 5-3	52, 53
APPENDIX	A. REFERENCES -----	-----	56
	B. ORGANIZATIONAL MAINTENANCE REPAIR PARTS AND SPECIAL TOOLS LISTS-----	-----	58
	Tools and equipment (fig. B-1)-----	-----	65
	C. MAINTENANCE ALLOCATION CHART -----	-----	66

APPENDIX B

BASIC ISSUE ITEMS LIST

AND

**ITEMS TROOP INSTALLED OR
AUTHORIZED LIST**

AND

REPAIR PARTS

AND

SPECIAL TOOLS LIST

Section I. INTRODUCTION

B-1. Scope

This appendix lists basic issue items, items troop installed or authorized, and repair parts and special tools required by the crew/operator for operation, and for the performance of organizational maintenance of the Rocket Launcher M20A1/M20A1B1.

B-2. General

These basic issue items, items troop installed or authorized, and repair parts and special tools lists are divided into the following sections:

a. Basic Issue Items List. Not applicable.

b. Items Troop Installed or Authorized List--Section II. A list, in alphabetical sequence, of items required by the operator for sustained operation of the end item. These discretionary items will be requisitioned by the unit in accordance with its mission requirements. They may accompany the end item, but are not subject to be turned in with it.

c. *Repair Parts List*. Not applicable.

d. *Special Tools List--Section III*. A list of special tools, test, and support equipment authorized for the performance of maintenance at the organizational level.

e. *Federal Stock Number and Reference Number Index*. Not applicable.

B-3. Explanation of Columns

The following provides an explanation of columns found in the tabular listings.

a. *Source, Maintenance, and Recoverability Codes (SMR)*.

(1) *Source code*. This code indicates the source for the listed item. Source codes, the first and second positions of the SMIR Code, are as follows:

<i>Code</i>	<i>Explanation</i>
PA	Item procured and stocked for anticipated or known usage.
PB	Item procured and stocked for insurance purposes because essentiality dictates that a minimum quantity be available in the supply system.
PC	Item procured and stocked and which otherwise would be coded PA except that it is deteriorative in nature.
PE	Support equipment procured and stocked for initial issue or outfitting to specified maintenance repair activities.
PF	Support equipment which will not be stocked but which will be centrally procured on demand.
KD	An item of depot overhaul/repair kit and not purchased separately.
KF	An item of a maintenance kit and not purchased separately.
KB	Item included in both a depot overhaul/repair kit and a maintenance kit.
MO	Item to be manufactured or fabricated at organizational maintenance level.
NF	Item to be manufactured or fabricated at direct support maintenance level.
MH	Item to be manufactured or fabricated at general support maintenance level.
MD	Item to be manufactured or fabricated at depot maintenance.
AO	Item to be assembled at organizational maintenance level.
AF	Item to be assembled at direct support maintenance level.

<i>Code</i>	<i>Explanation</i>
AH	Item to be assembled at general support maintenance level.
AD	Item to be assembled at depot maintenance level.
XA	Item is not procured or stocked. The requirements for the item will be filled by requisitioning the next higher assembly.
XB	Item is not procured or stocked. If not available through salvage, requisition from the end-item manager, with exception data, for immediate use.
XC	Installation drawing, diagram, instruction sheet, field service drawing, that is identified by manufacturer's part number.
	(2) <i>Maintenance code.</i>
	(a) <i>Use code.</i> This code, the third position of the SMR code, indicates the lowest category of maintenance authorized to remove, replace, and/or use the item. Capabilities of higher maintenance categories are considered equal or better. The maintenance use codes are: Code Explanation C Item removed, replaced, and/or used by the crew/ operator.

<i>Code</i>	<i>Explanation</i>
O	Item removed, replaced, and/or used at organizational maintenance.
F	Item removed, replaced, and/or used at direct support maintenance.
H	Item removed, replaced, and/or used at general support maintenance.
D	Item removed, replaced, and/or used at depot maintenance only.
	(b) <i>Repair code.</i> This code, the fourth position of the SMR code, indicates whether the item is to be repaired and identifies the lowest maintenance level with the capability to perform complete repair (i.e., all authorized maintenance functions). This does not preclude some repair which may be accomplished at a lower level of maintenance. The maintenance repair codes are:

<i>Code</i>	<i>Explanation</i>
0	The lowest category capable of complete repair is organizational maintenance.
F	The lowest category capable of complete repair is direct support maintenance.
H	The lowest category capable of complete repair is general support maintenance.

<i>Code</i>	<i>Explanation</i>
D	The only category capable of complete repair is depot maintenance.
L	Repair restricted to a designated specialized repair activity.
Z	Nonreparable. No repair is authorized.
B	No repair is authorized. The item may be reconditioned by adjusting, lubricating; etc., at the user level. No parts or special tools are procured for the maintenance of this item.

(3) *Recoverability code.* This code indicates whether unserviceable items should be returned for recovery or salvage. The recoverability codes, the fifth position of the SMIR code, are as follows:

<i>Code</i>	<i>Explanation</i>
Z	Nonreparable item. When unserviceable, condemn and dispose at the level indicated by maintenance use code (third position).
O	Reparable item. When uneconomically reparable, condemn and dispose at organizational maintenance.
F	Reparable item. When uneconomically reparable, condemn and dispose at direct support maintenance.
H	Reparable item. When uneconomically reparable, condemn and dispose at general support maintenance.
D	Reparable item. When beyond lower level repair capability, return to depot. Condemnation and disposal not authorized below depot maintenance.
L	Reparable item. Repair, condemnation, and disposal not authorized below depot/specialized repair activity.
A	Item requires special handling or condemnation procedures because of specific reasons (i.e., precious metal content, high dollar value, critical or hazardous material). Refer to appropriate manuals/directives for specific instructions.

b. Federal Stock Number. This designation indicates the Federal stock number assigned to the item and will be used for requisitioning purposes.

c. Description. This designation indicates the Federal item name and a minimum description required to identify the item. The last line indicates the reference number followed by the applicable Federal supply code for manufacturer (FSCM) in parentheses. The FSCM is

used as an element in item identification to designate manufacturer, distributor, or Government agency; etc., and is identified in SB 708-42.

d. Unit of Measure (U/M). This designation indicates the standard or basic quantity by which the listed item is used in performing the actual maintenance function. This measure is expressed by a two-character alphabetical abbreviation; e.g., ea for each, and is the basis used to indicate quantities. When the unit of measure differs from the unit of issue, the lowest unit of issue that will satisfy the required units of measure will be requisitioned.

j. Quantity Authorized. This designation indicates the quantity of the item authorized to be used with the equipment.

g. Quantity Incorporated in Unit. Indicates the quantity of the item used in that functional group/assembly. A V appearing in this column in lieu of a quantity indicates that no specific quantity is applicable; e.g., shims, spacers; etc.

h. Allowance Columns.

(1) *Repair parts list.* The allowance columns are left blank intentionally. The maintenance level code indicates that the item is authorized for use at that category. Organizational parts will be requisitioned on an as-required basis until authorized stockage levels are established based on demand criteria.

(2) *Special tools list.* The allowance columns are divided into four subcolumns. Indicated in each subcolumn is the total quantity of tools authorized for the number of equipments supported. Items authorized for use as required, but not for initial stockage, are identified with an asterisk (*) in the allowance column.

i. Illustration. This column is divided as follows:

(1) *Figure number.* Indicates the figure number of the illustration on which the item is shown.

(2) *Item number.* Indicates the callout number used to reference the item on the illustration.

Section II. ITEMS TROOP INSTALLED OR AUTHORIZED LIST

(1) Federal stock No.	(2) Description <i>Reference number & Mfr. Code</i>	(3) Unit of meas	(4) Qty auth
4933-714-9835	WRENCH AND SCREWDRIVER COMBINATION: 7149835 (19204).	ea	1

Section III. SPECIAL TOOLS LIST

(1) Source maint and recov code			(2) Federal stock No.	(3) Description Reference number & mfr code	(4) Unit of meas	(5) Qty inc in unit	(6) 15 day organizational maintenance alw				(7) Illustration	
(a) Source	(b) Maint	(c) Recov					(a) 1-5	(b) 6-20	(c) 21-50	(d) 51-100	(a) Figure No.	(b) Item No.
PACZZ			4933-714-9835	WRENCH AND SCREWDRIVER COMBINATION: 7149835 (19204).	ea		*	1	3	5	B-1	2

By Order of the Secretary of the Army:

CREIGHTON W. ABRAMS
General, United States Army
Chief of Staff

Official:
VERNE L. BOWERS
Major General, United States Army
The Adjutant General

Distribution:

To be distributed in accordance with DA Form 12-40, (Qty Rqr Block No. 34) Organizational Maintenance Requirements for Launcher, Rocket, 3.5-Inch, M20A1, M20A1B1.

SAFETY PRECAUTIONS

WARNING HANDLING AMMUNITION

Undue shock in handling ammunition or exposure to high temperature could result in death or injury to personnel if the rockets would accidentally fire.

WARNING DANGEROUS CONDITIONS

The blast of flame to the rear of the launcher and the rearward flight of nozzle closures and/or igniter wires could result in death or injury to personnel remaining in Zone "A". Zone "B" is also hazardous unless adequate shelter is available.

The blowback of propellant particles after rockets M28A2 (HEAT), M29A2 (PRACTICE), and T127E2 and M30 (SMOKE) are fired, could result in serious injury to personnel in the "backblast areas" unless protected by goggles and other acceptable face and hand protection.

Rockets with loose nozzle closures must not be fired. Careful attention must be given when examining rockets for loose closures. Rockets that contain loose heads or contain a gap between the head and fuze should not be fired as this will cause the rocket to fall short and could cause injury to personnel.

When the rocket does not fire and a slight noise is heard and a small puff of smoke is released, make certain to keep the launcher trained on the target and observe all precautions for firing for a 2minute period. Then remove rocket and return it to segregated ammunition storage, in its original container indicating the condition.

WARNING
DANGEROUS PROCEDURES

When using gasoline to dispose of materiel, due consideration should be given to its highly flammable nature and vapor. Carelessness in its usage could result in painful burns. When disposing of materiel by gunfire (artillery) at ranges 500 yards or less or using rifle grenades or antitank rockets make certain to take cover.

When rotating rockets M28A2, M29A2, T127E2 or M30 (T127E3) within the launcher tube, make certain to rotate clockwise only, as viewed from rear of launcher. This will eliminate the possibility of unscrewing the head of the rocket from the fuze and if the rocket is fired in this condition may fall short and cause injury to personnel.

When loading or before firing make certain the safety switch of the trigger grip on the electrical firing mechanism is in "SAFE" position.

Changes in force: C1

CHANGE
No. 1



HEADQUARTERS
DEPARTMENT OF THE ARMY
WASHINGTON, D.C., 21 November 1972

**Operator and Organizational Maintenance Manual
Including Repair Parts and Special Tool Lists**

**LAUNCHER, ROCKET, 3.5-INCH M20A1, WIE
(1055-840-1 841)**

AND

**LAUNCHER, ROCKET, 3.5-INCH M20A1Bi, WIE
(1055-840-1 842)**

TM 9-1055-201-12, 9 October 1968, is changed as follows:

Page 3. Paragraph 1-2*b* is superseded as follows:

b. Reporting of Equipment Publication Improvements. The reporting of errors, omissions, and recommendations for improving this publication by the individual user is encouraged. Reports should be submitted on DA Form 2028 (Recommended Changes to Publications) and forwarded direct to: Commander, US Army Weapons Command, ATTN: AMSWE-MASSP, Rock Island, IL 61201.

Page 6. Add the following at end of paragraph 1-3: One small arms sling, M1 (1, fig. B-1) is issued as a component of each launcher.

Page 13. Table 2-3 is superseded as follows:

Table 2-3. Expendable and Consumable Supplies

<i>FSN</i>	<i>Item</i>
7920-205-2401	BRUSH, CLEANING, TOOL AND PARTS: Round, 100 per cent Tampico fiber, 1 $\frac{1}{16}$ at ferrule brush diam, 2 $\frac{7}{8}$ clear of block brush lg, MS16746-29 (96906).
6850-965-2332	CARBON REMOVING COMPOUND: (P-C-111) (81348) 5 gal pail.

Table 2-3. Expendable and Consumable Supplies-Cont.

<i>FSN</i>	<i>Item</i>
6850-392-9751	CLEANING COMPOUND, OPTICAL LENS: Liquid, 1 oz bottle. CLEANING COMPOUND, RIFLE BORE: MIL-C-372 (81349) (RBC).
6850-224-6656	2 oz bottle.
6850-224-6657	8 oz can.
6850-224-6663	1 gal can.
5350-221-0872	CLOTH, ABRASIVE: Crocus, ferric oxide and quartz, jean-cloth-backing, closed coating, 9 inches wide by 11 inches long 50-sh-sleeve P-C-458 (81348) (CA).
6850-281-1985	DRY CLEANING SOLVENT: P-D-680 (81348) (SD) 1 gal can.
8010-297-2105	ENAMEL: Olive drab, semi-gloss, 1 gal can TT-E-485. LUBRICATING OIL, GENERAL PURPOSE: VV-L-800 (81348) (PL special).
9150-273-2389	4 oz can.
9150-231-6689	1 qt can.
9150-292-9689	LUBRICATING OIL, WEAPONS: MIL-L-14107 (81349) (LAW) for below zero operations (1 qt can).
6640-162-2993	PAPER, LENS: 4% inches wide by 5 inches long, 100 sheet book NNN-P-40 (81348).
7920-205-1711	RAG, WIPING: Cotton, for general purpose use (50 lb bale) DDD-R-30, class 2 (81348).

Page 24. Paragraph 3-3, line 3. Change the symbol (CR) to (RBC).

CHAPTER 1 INTRODUCTION

Section I. GENERAL

1-1. Scope

This manual contains instructions for the operation and organizational maintenance of Launcher, Rocket, 3.5-Inch, M20A1, and Launcher Rocket, 3.5-Inch, M20A1B1 as prescribed by the maintenance allocation chart (app. B).

1-2. Forms and Records

a. General. DA Forms and procedures used for equipment maintenance will be only those prescribed in TM 38-750, Army Equipment Record Procedures.

b. Recommendations for Maintenance Manual Improvements. Reports of errors, omissions, and recommendations for improving this manual by the individual user is encouraged. Reports should be submitted on DA Form 2028 (Recommended Changes to DA Publications) and forwarded direct to:

Commanding General, Headquarters, U.S. Army Weapons
Command, ATTN: AMSWE-SMM-P, Rock Island, Ill.
61201.

Section II. DESCRIPTION AND DATA

1-3. Description

The Rocket Launchers M20A1 (fig. 1-1) and M20A1B1 (fig. 1-2) are two-piece smooth-bore weapons of the open tube type and are fired by an electrical firing mechanism, which contains a magneto that provides the current and is located in the trigger grip. These launchers are designed to be fired from the shoulder in standing, kneeling, sitting, or prone position. To reduce weight, the barrels and many of the components are made of aluminum. These launchers are designed to

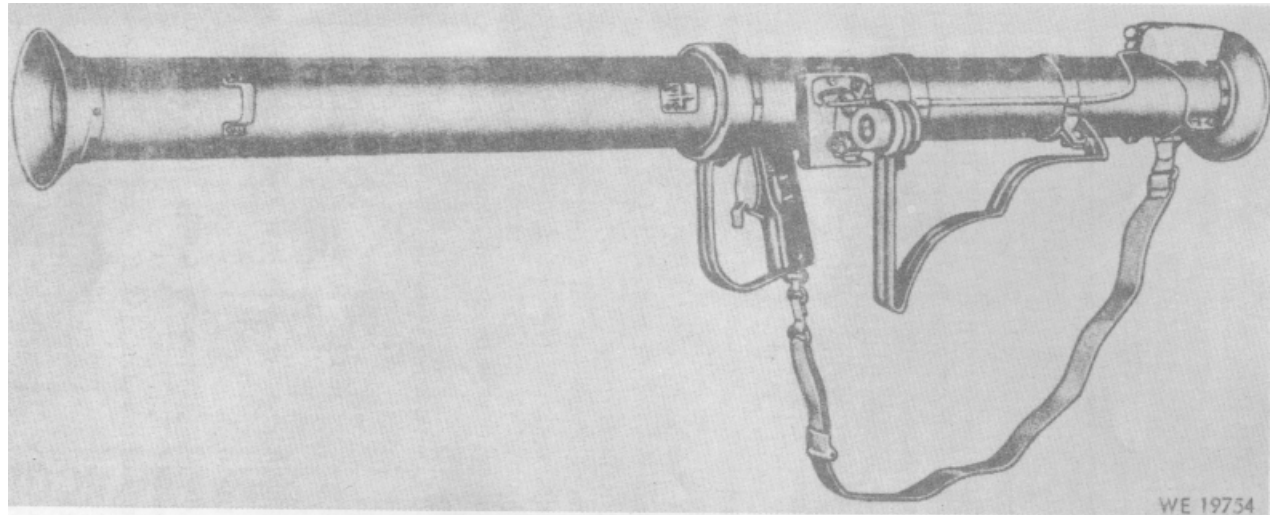

Figure 1-1. 3.5-Inch Rocket Launcher M20A1.

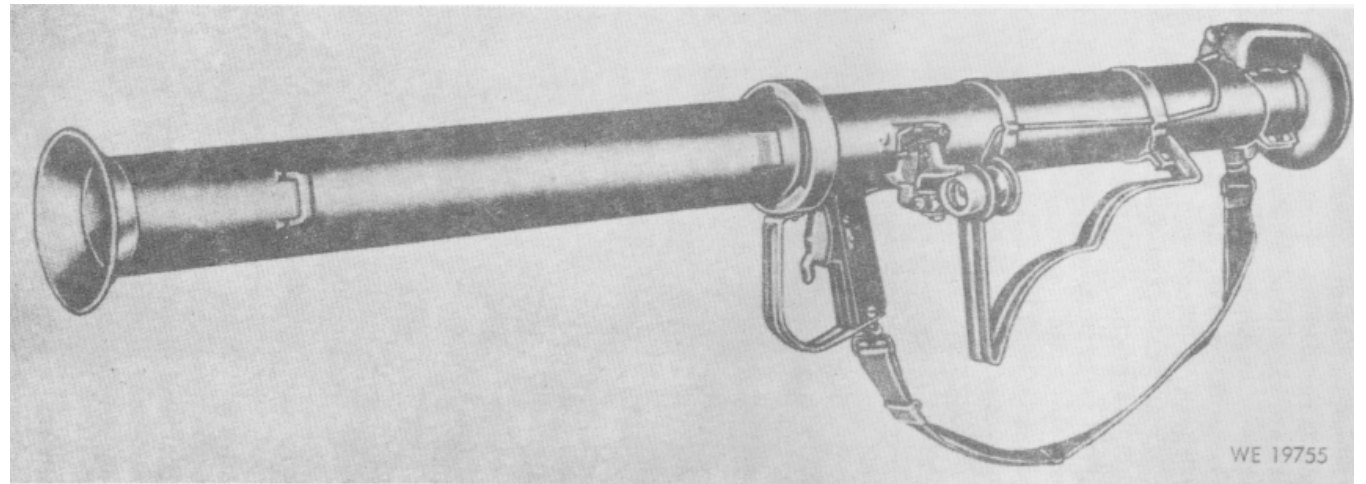

Figure 1-2. 3.5-Inch Rocket Launcher M20A1B1.

launch high-explosive rockets and smoke rockets against ground targets. These high-explosive antitank rockets are capable of penetrating heavy armor at angles of impact greater than 30 degrees. The barrels are fastened together (fig. 1-3) for carrying purposes, utilizing the gun sling. For convenience of maintenance and repair, the launchers are divided into groups and assemblies as indicated in figure 1-4.

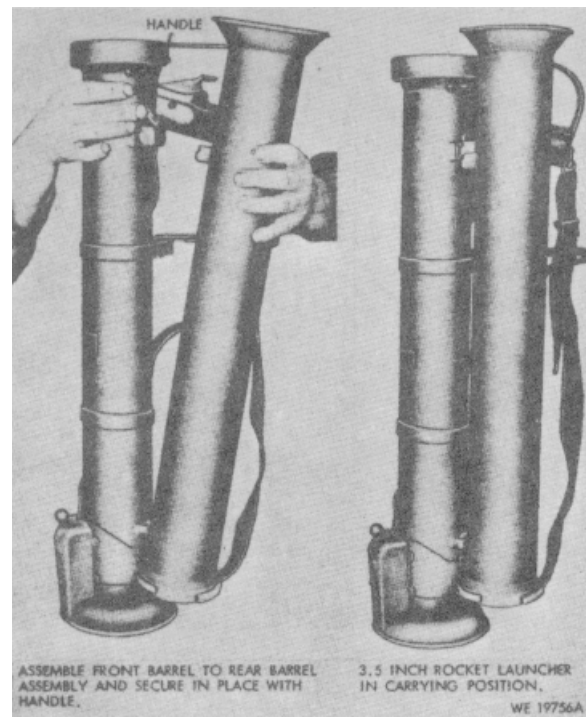

Figure 1-3. Barrels assembled for carrying.

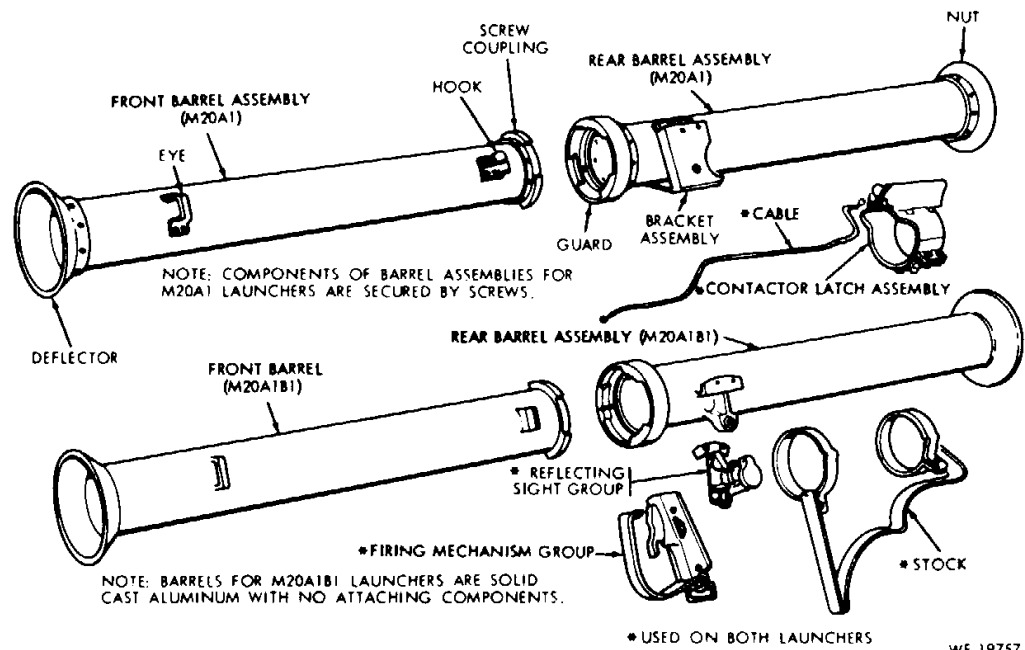

Figure 1-4. 3.5-Inch Rocket Launchers M20A1 and M20A1B1-groups and assemblies.

1-4. Tabulated Data

a. Launcher

	M20A1	M20A1B1
Length (assembled for firing)	60 in.....	60 in.
Weight	14	13 lb.
Length of front barrel	30 in.....	30 in.
Weight of front barrel	4.5 lb.....	4 lb.
Length of rear barrel	30 in.....	30 in.
Weight of rear barrel	9.5 lb.....	9 lb.
Type of firing mechanism.....	Electrical.....	Electrical.
Maximum effective range.....	300 yd.....	300 yd.
(point type targets).....	(275M).....	(275M).
Maximum effective range.....	200 yd.....	200 yd.
(moving type targets).....	(185M).....	(185M).
Muzzle velocity.....	334 fps.....	334 fps.
Range (max) (approx).....	900 yd.....	900 yd.

b. Sling

Weight	0.24 lb.....	0.24 lb.
--------------	--------------	----------

c. Ammunition

Types.....	HE, AT, WP, and Practice.
Weight of rocket (approx)	9 lb.
Armor penetration	Armor plate 11 inches, homogeneous.

1-5. Identification

The model and serial number are stamped on tile rear barrel assembly of the rocket launchers.

1-6. Differences in Models

Refer to figure 1-4.

Note. The front barrels are not to be interchanged, inasmuch as the launcher loses its original identity.

**CHAPTER 2
OPERATING INSTRUCTIONS**

Section I. SERVICES UPON RECEIPT OF MATERIEL

2-1. General

a. When a new or reconditioned launcher is received, it is the responsibility of the officer in charge to determine whether the materiel has been properly prepared for service by the supplying organization and to be sure it is in condition to perform its function.

b. A record will be made of all missing parts, tools and equipment and any malfunctions. Corrective action will be initiated as quickly as possible.

2-2. Services

Refer to table 2-1.

<i>Table 2-1. Service Upon Receipt of Materiel</i>		
Step	Action	Reference
1	Check shipping container for legibility and accuracy of marking and method of packaging.	
2	Remove steel straps from the container.	
3	Remove launchers from the container.	
4	Check the tags on the front and rear barrel assemblies. The assemblies, that were boresighted together, will be identified by the tags.	
5	Remove the tape and grease proof barrier materials from the assemblies.	
6	Remove preservatives with wiping cloths.	
7	Wash launcher, except firing mechanism, with dry cleaning solvent (SD).	

Step	Action	Reference
8	Lubricate -----	Para 3-3 and 3-4.
9	Visually inspect each launcher for damage, loose, or missing parts. Make an operational check of the contactor latch assembly, coupling lock group, barrel latch assembly, trigger, and safety switch.	

Section II. CONTROLS

2-3. General

a. This section describes, locates, and illustrates the various controls provided for operation and maintenance of the rocket launchers.

b. Refer to table 2-2 for controls.

Table 2-2. Controls

Control	Function	Reference
Trigger.....	When the trigger is actuated, a magnetic armature is placed in motion. This activates the firing mechanism and generates the electrical current used to ignite the rocket.	Figure 2-1.
Safety switch.	The safety switch has two positions, SAFE and FIRE. In the lower (SAFE) position, a block on the safety mechanism prevents the trigger from moving. In the upper (FIRE) position, the block is held clear of the lug on the trigger and the trigger is free to move.	Figure 2-1.

Control	Function	Reference
Coupling lock lever.	Used to release the coupling locks when disassembling or assembling the front and rear barrel assemblies. The lever is operated by raising and holding the lever in its unlocked position. When released, a spring returns it to the locked position.	Figure 2-2.
Barrel latch handle.	Used to release or lock the barrel latch, which locks or unlocks the front and rear barrel assemblies.	Figures 1-3 and 2-2.
Linkage assembly.	The linkage assembly is a component of the contactor latch assembly and controls the loading and the firing of the launchers.	Figure 2-3.

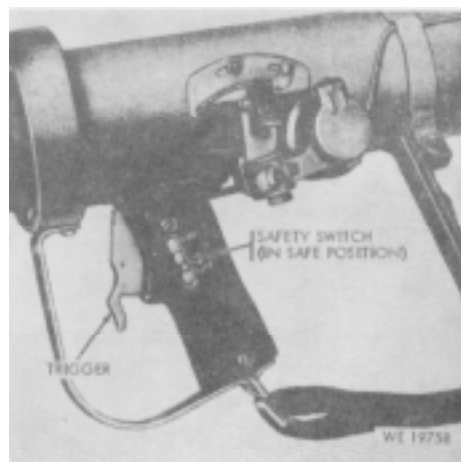

Figure 2-1. Trigger and safety switch.

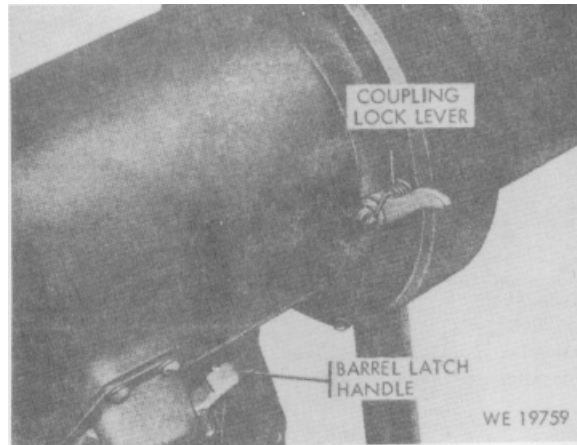

Figure 2-2. Coupling lock lever and barrel latch handle.

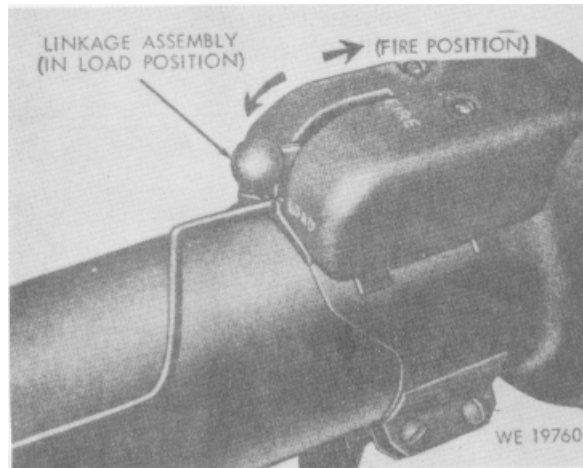

Figure 2-3. Linkage assembly.

Section III. OPERATION UNDER USUAL CONDITIONS

2-4. General

This section contains a step-by-step procedure for operating the launchers under conditions of moderate temperatures and humidity. For operation under unusual conditions., refer to section IV.

2-5. Preparation for Firing

- a. Release barrel latch handle and disengage the front barrel or front barrel assembly.
- b. Install the barrels (fig. 2-4).
- c. Unfold the reflecting sight assembly and set the sight for a specific range.
- d. Prepare ammunition for firing (para 4-7).

2-6. Service Before Firing

- a. Refer to table 2-3 for cleaning and lubrication materials and stock numbers for requisitioning purposes.

Table 2-3. Materials Required for .Maintenance Functions

FSN	Item
7920-205-2401	BRUSH, CLEANING, TOOL AND PARTS: round, 100 per cent Tampico fiber, 1 $\frac{1}{16}$ at ferrule brush dia, 2 $\frac{7}{8}$ clear of block brush lg.
6850-965-2332	CARBON REMOVING COMPOUND: (P-C-11) 5 gal pail.
6850-262-8606	CLEANING COMIPOUND, OPTICAL LENS: liquid, 1 oz bottle.
6850-224-6656	CLEANING COMPOUND, RIFLE BORE (CR): 2 oz can.
6850-224-6657	6 oz can.
6850-224-6658	1 qt can.
6850-224-6663	1 gal can.
5350-221-0872	CLOTH, ABRASIVE: crocus, ferric oxide and quartz, jean-cloth-backing, closed coating, 9 w, 11 lg, 50-sh-sleeve (CA).
6850-281-1985	DRY CLEANING SOLVENT: liquid (SD) 1 gal can.
8010-297-2105	ENAMEL: olive drab, semi-gloss, 1 gal can.
	LUBRICATING OIL, GENERAL PURPOSE (PL, special):
9150-273-2389	4 oz can.
9150-231-6689	1 qt can.
9150-292-9689	LUBRICATING OIL, WEAPONS: (LAW) for below zero operations, 1 qt can.
6640-162-2993	PAPER, LENS: 4 $\frac{1}{2}$ w, 5 lg, 100 sheet book.
7920-205-1711	RAG, WIPING: cotton, for general purpose use, 50 lb bale.

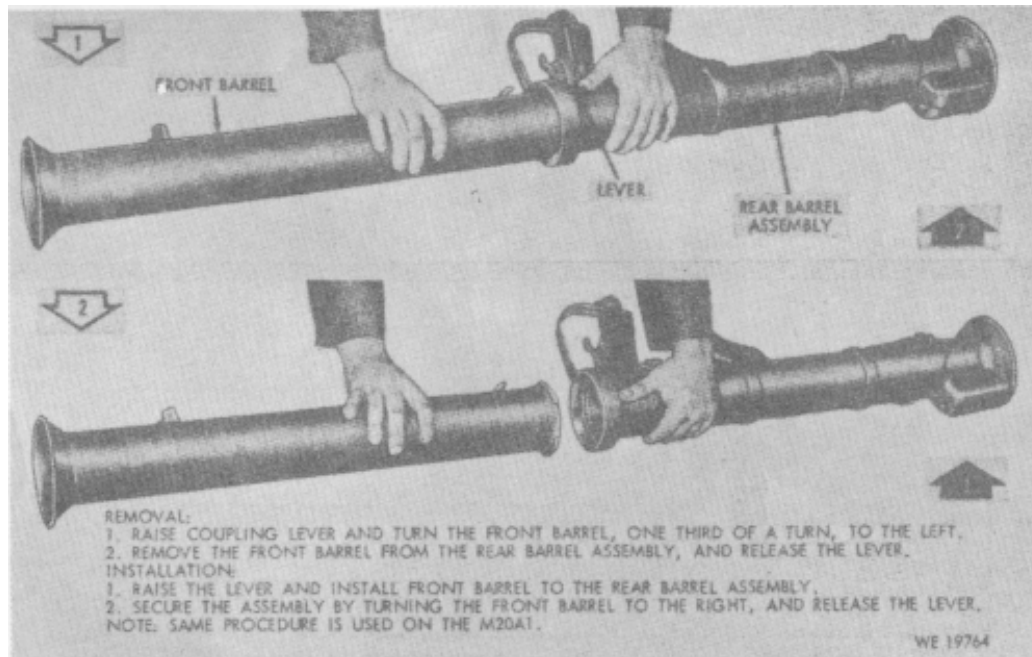

Figure 2-4. Removal and/or installation of front barrel.

b. Perform the before firing operations as indicated in table 3-2, Preventive Maintenance Checks and Services.

2-7. Loading

a. *Gunner*

(1) The gunner places the launcher on his right shoulder and points at the target area.

(2) Sets the SAFETY in the SAFE position.

(3) Commands the loader to LOAD.

b. *Loader*

(1) The loader checks the rocket for a loose nozzle closure by gently pulling the red and green ignition wire leads which pass through the closure (fig. 4-1). Any movement of the closure indicates that it has not been sealed properly. A loose closure may result in the rocket falling short or "chuffing" (intermittent burning with a puffing noise) when fired. A chuffing rocket may fall to the ground a short distance from the launcher, smolder, and then resume burning and be propelled in an unpredictable direction.

Warning. Rockets with loose nozzle closures must not be fired. Special attention must be given to examining the nozzle closure during wet or freezing weather. Any rocket in which the head moves with respect to the fuze, or has a gap between the head and fuze, is not to be fired. Any rocket showing either of the above conditions will be returned to segregated ammunition storage in a properly marked container indicating the condition.

(2) Remove the shorting clip from the contact ring assembly of the rocket.

Caution. When loading the rocket into the launcher, depress the ejection pin (fig. 2-5) with the fingers until the pin is in the bore of the launcher. Make sure that the pin is pointed downward or to the side. Failure to hold the ejection pin depressed, while loading the rocket, may result in the pin coming in contact with the breech end of the launcher tube and thereby

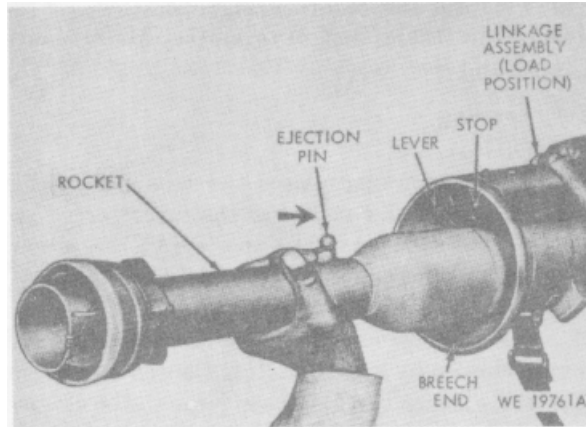

Figure 2-5. Loading the launcher

becoming bent. Failure to point the ejector pin downward or to the side may result in the pin striking the position stops and becoming bent. Observance of these procedures gives greater assurance of proper functioning of the rocket.

(3) Move the control handle of the launcher forward to the "LOAD" position (fig. 2-5). Remove the safety band from the fuze, and carefully push the rocket into the launcher tube until the lever engages the continuous groove in the support ring. Two spring-loaded stops will properly position the rocket inside the launcher.

Note. Never rain the rocket into the launcher. Precise unhurried loading prevents the stops from over riding the fin assembly, or allowing the rocket to move too far forward into the barrel.

(4) Move the control handle to the "FIRE" position. The launcher is now ready to be fired.

2-8. Boresighting and Sighting

a. *Boresighting.* The purpose of boresighting is to test the alinement of the reflecting sight with respect to the bore of the launcher. The using personnel will boresight the weapon by the distant target method. Boresighting must be performed anytime a barrel or a sight is

replaced or if the launcher has been dropped or subjected to rough handling.

(1) The target may be any point on distant terrain, 1,500 yards or more from the launcher.

(2) Boresighting notches appear on the rim of the muzzle deflector of the launcher (spaced 90 degrees apart). Install two lengths of string as cross hairs across the muzzle, locating them in the bore sighting notches on the rim of the muzzle deflector. Remove the wooden disk, which has a $\frac{1}{8}$ -inch hole drilled in the center, from the ammunition container and insert it in the rear of the launcher as a boresight plug. Sight through the hole in the plug and aline the launcher so that the distant target appears exactly in the lower right quadrant, with the top of the target touching the horizontal cross hair and the left side of the target touching the vertical cross hair. The launcher must be set firmly in this position.

(3) Set the indicator arm at "0" on the elevation plate, and sight through the reflecting sight assembly. If the image of the target is not touching the "0" horizontal lead line and the left side of the target is not touching the vertical line, the reflecting sight assembly is out of alinement. To aline vertically loosen the elevation plate screws and adjust the elevation plate to the desired position. To aline laterally, loosen the hinge stud nut, and turn the hinge stud to the correct position. When correctly alined, the target should be centered in both the reflecting sight assembly and the launcher bore.

b. *Sighting.* (Fig. 2-6.) To fire at any target between 0 and 450 yards range, set the indicator arm at the mark on the elevation plate which reads 0 to 450. Select the horizontal line with the desired range and use it for aiming. If the target has a range greater than 450 yards, set the indicator arm on the desired range and use the zero horizontal line for aiming.

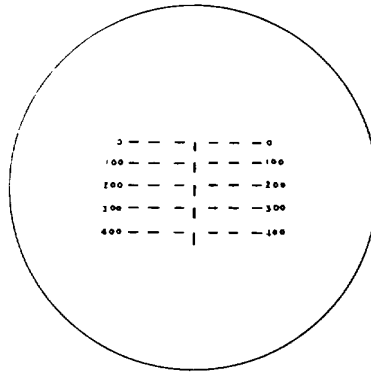

LADDER TYPE RETICLE PATTERN

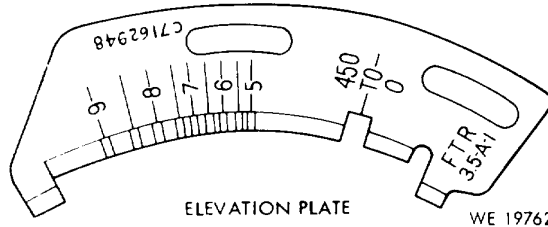

Figure 2-6. Sighting--use of elevation plate and reticle pattern.

2-9. Firing

Warning. Before firing a rocket, the area to the rear of the launcher should be cleared as indicated for zones A and B in figure 2-7. Zone "A", the blast area, should be clear of all personnel, ammunition, materiel, and flammables, such as dry vegetation. The danger in this area is from the blast of flame to the rear of the launcher and the rearward flight of nozzle closures and/or igniter wires. Zone "B", should be clear of all personnel, ammunition, and materiel unless protected by adequate shelter. The principal danger in this zone is from the rearward flight of nozzle closures and/or igniter wires.

Note. An additional safety factor for training is obtained by Zone C.

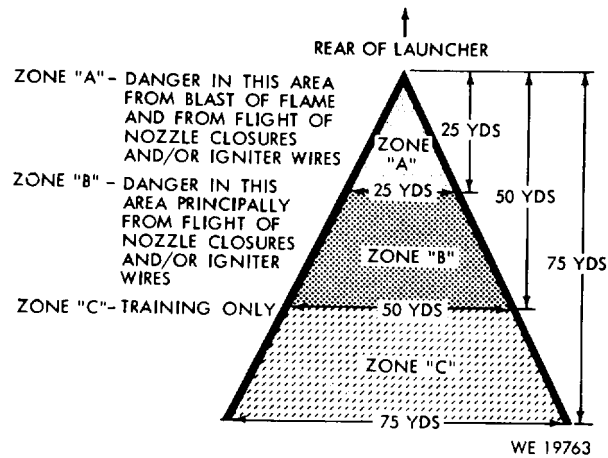

Figure 2-7. Danger zone diagram.

Warning. Since the rocket may burn for a time after projection from the launcher thereby placing the operating personnel in the "backblast" areas, eye protection in the form of goggles or similar equipment with safety glass lenses is mandatory at temperatures of 70°F, and above. At temperatures below 70°F, rockets of M28A2 (HEAT) and M29A2 (PRACTICE) and rockets T127E2 and M30 (SMOKE) may be expected to produce blowback of propellant particles after projection from the launcher. Therefore, at temperatures below 70°F., the use of field protective mask or goggles and hand protection is mandatory for all operating personnel. All field masks or goggles used for these rocket firings must be distinctively identified by attaching DA Form 2402 (Exchange Tag) or comparable blank tag to the head harness. One side of the tag will be marked in pen with the stock number and nomenclature of the mask while the reverse side will be marked in pen with the following: "Used in rocket launcher firing; prior to CBR use, inspect in accordance with SB 3-30-10 and repair as necessary." The identification tag will be removed at the time of inspection only if the mask is acceptable for CBR use.

Serviceability of masks, when used for rocket firings, should be based solely on consideration of vision and facial protection afforded and sanitation.

a. Move the safety to the "FIRE" position and squeeze the trigger to fire the rocket. Maintain sight picture until rocket has cleared the tube.

b. Care should be exercised when firing near bushes and trees, since impact with a twig or branch may deflect the rocket while a heavy branch may detonate the rocket.

2-10. Misfire and Hangfire

a. *Misfire.* When a misfire occurs, due to incomplete electrical circuit, perform the immediate action described in (1) through (3) below:

(1) Keep the launcher trained on the target and make two additional attempts to fire.

(2) If rocket still fails to fire, wait 15 seconds from the last attempt to fire. Remove the rocket and check firing contact and contactor latch blade for possible malfunctions. Make certain parts are clean and free of rust or corrosion.

***Warning.* If it is necessary to rotate rockets M28A2, M29A2, T127E2 or M30 (T127E3) within the launcher tube to insure electrical contact, rotate in a clockwise direction only, viewed from the rear of the launchers, to eliminate the possibility of unscrewing the head of the rocket from the fuse.**

(3) After making any necessary adjustment, again make three attempts to fire. If the rocket still fails to fire, wait 15 seconds before removing the round and return it to segregated ammunition storage in a properly marked container indicating the condition.

b. *Hangfire.* A hangfire is a delay in the functioning of a propelling charge at the time of fire. When a hangfire is suspected the following warning should be observed.

***Warning.* If a slight noise is heard and a small puff of smoke is emitted from the rear of the launcher, during an attempt to fire, this indicates the igniter has functioned but has failed to ignite the propellant. If this is the case, it is mandatory to keep the launcher**

trained on the target and to observe all the precautions for firing for a 2-minute period. At the end of this period, remove the rocket and return it to segregated ammunition storage in a properly marked container indicating the condition. Be sure that the safety is in the "SAFE" position, except when actually squeezing the trigger.

2-11. Services

Perform the services as indicated in table 3-2, Preventive Maintenance Checks and Services.

2-12. Unloading

a. Move the control handle to "LOAD" position and withdraw the rocket from the launcher in the following manner:

- (1) Raise detent and remove the rocket.
- (2) Replace safety band over the ejection pin and shorting clip.

- (3) Prepare rocket for repacking and disposal.

b. Hold ejection pin back, when removing rocket from launcher.

c. The rocket is armed and must be handled nose up with extreme care, when the ejection pin is not in place.

2-13. Preparation of the Launchers for Carrying

Refer to figures 2-4 and 1-3.

Section IV. OPERATION UNDER UNUSUAL CONDITIONS

2-14. General Conditions

a. In addition to the normal operating procedures for usual conditions, special instructions for operation under unusual conditions are contained herein. In addition to the normal preventive-maintenance service, special care in cleaning and lubrication must be observed where extremes of temperature, humidity, and atmospheric conditions are present or anticipated. Proper cleaning, lubrication, storage, and

handling of lubricants not only insure operation and functioning but also guard against excessive wear of the working parts and deterioration of the material.

b. See paragraph 3-4 for instructions on lubrication under unusual conditions; table 3-1 and paragraphs 3-5 and 3-6 for preventive-maintenance checks and services.

c. When chronic failure of material results from subjection to extreme conditions, report of such chronic failure should be made in accordance with paragraph 1-2.

2-15. Operation in Extreme Cold

a. In climates where the temperature is consistently below freezing, it is necessary to prepare the materiel for cold-weather operation.

b. Exercise the various controls through their entire range at intervals as required, to aid in keeping them from freezing in place and to reduce the effort required to operate them.

c. When materiel is not in use, pay particular attention to protecting it with the proper covers, making certain they are serviceable, in good state of repair, and are securely fastened so that snow and ice will be kept from the operating parts. Provide as much protection as possible for all parts of the materiel and equipment.

2-16. Operation in Extreme Heat

a. *General.*

(1) In hot climates, the film of oil necessary for operation and preservation will dissipate quickly. Inspect materiel frequently, paying particular attention to all hidden surfaces, such as the bore, springs and spring seats, firing mechanism, and contactor latch assembly, and like places, where corrosion might occur and not be quickly noticed.

(2) Perspiration from the hands is a contributing factor to rusting because it contains acids and salts. After handling, clean, wipe dry, and restore the oil film.

(3) For care, handling, and preservation of ammunition, refer to paragraph 4-4.

b. *Hot, Dry Climates.* When operating in hot climates, clean and oil the bore of the rocket launcher more frequently than usual. Rapid temperature changes cause a moisture condensation film to form on unpainted aluminum, resulting in corrosion. Immediately, when this moisture film occurs wipe briskly until thoroughly dry and coat with general purpose lubricating oil (PL special) as required, to prevent rusting.

c. *Hot, Damp, and Salty Atmosphere.*

(1) Inspect materiel frequently, when operating in hot and/or moist areas.

(2) When materiel is active, clean and lubricate the bore and exposed metal surfaces more frequently than is prescribed for normal service.

(3) Moist and salty atmospheres have a tendency to emulsify oils and grease and destroy their rust-preventive qualities. Inspect all parts frequently for corrosion. Protect from elements as much of the time as firing conditions permit.

(4) When the materiel is inactive, store in a dry area. Keep protective covering in place.

(5) Presence of moisture will contribute to voltage leaks and interference between circuits.

**CHAPTER 3
OPERATOR AND ORGANIZATIONAL
MAINTENANCE INSTRUCTIONS**

Section I. TOOLS AND EQUIPMENT AND REPAIR PARTS

3-1. Tools and Equipment

Tools and equipment issued with or authorized for the operator and organizational maintenance are listed in appendix B.

3-2. Repair Parts

No repair parts are authorized for operator or organizational maintenance.

Section II. CLEANING AND LUBRICATION INSTRUCTIONS

3-3. Cleaning and Lubrication

a. Immediately after firing, clean all powder-fouled surfaces with rifle bore cleaning compound (CR). Clean the remaining components, with dry cleaning solvent (SD). Wipe dry and oil with general purpose lubricating oil (PL special). Thereafter, clean and oil every 90 days unless inspection reveals shorter intervals are required. Wipe clean before firing.

b. The contactor latch assembly will be lubricated with general purpose lubricating oil (PL special) as shown in figure 3-1.

c. The firing mechanism will be lubricated only by the armorer or under his supervision.

3-4. Lubrication Under Unusual Conditions

a. *Unusual Conditions.* Reduce lubrication intervals specified in the lubrication instructions to compensate for abnormal operation and extreme conditions, such as high or low temperatures, prolonged periods of high-rate operation, continued operation in sand or dust, or

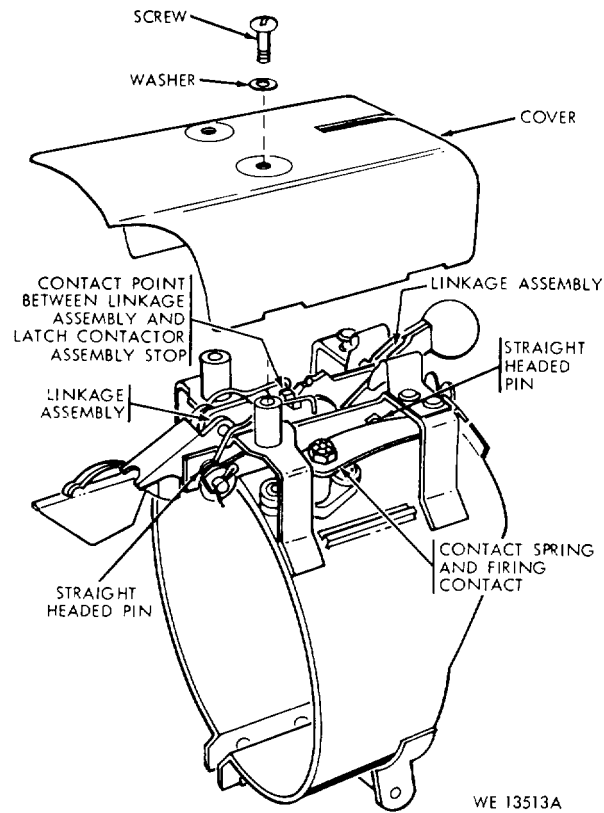

Figure 3-1. Lubrication points of contactor latch assembly.

exposure to moisture, any one of which may quickly (destroy the protective qualities of the lubricant.

b. Extreme Cold-Weather Lubrication. In extreme cold weather lubricate the launchers with lubricating oil (LAW).

c. Extreme Hot-Weather Lubrication. In extreme hot weather lubricate the launchers with general purpose lubricating oil (PL special). However, more frequent servicing is necessary than specified in table 3-1 because the heat tends to dissipate the lubricants.

d. Lubrication for Humid and Salt-Air Conditions. High humidity, moistures or salt air contaminate lubricants, necessitating more frequent

service than specified in table 3-1.

e. After Immersion Lubrication. After immersion clean and lubricate the launcher and allow to dry thoroughly.

f. Lubrication After Operation Under Sandy or Dusty Conditions. If firing or prolonged travel has occurred under dusty or sandy conditions, clean and inspect all lubricated surfaces for fouled lubricants. Lubricate as necessary.

Section III. PREVENTIVE MAINTENANCE CHECKS AND SERVICES

3-5. General

Preventive maintenance is a systematic care, inspection, and servicing of equipment to maintain it in serviceable condition, prevent breakdowns and assure maximum operational readiness. The operator's role in performance of preventive maintenance service is:

- a.* To perform the daily service each day the launchers are operated.
- b.* To assist the unit armorer perform any scheduled periodic services which are authorized to them.

3-6. Specific Procedures

a. Table 3-1 gives the specific procedures to be performed by operator and unit armorer.

b. In addition to procedures outlined in table 3-1, perform the following: Remove rust, dirt, grit, gummed oil and water as these will cause rapid deterioration of the internal mechanism and outer surfaces. Particular care should be taken to keep all surfaces clean and lubricated.

c. Loose parts will be tightened.

d. Every six months check to see if all modifications have been applied. Refer to DA Pam 310-7. No alteration or modification will be made except as authorized by the modification work order.

Table 3-1. Preventive Maintenance Checks and Services

Item Number	Interval						Item to be inspected	Procedure	Reference
	Operator-Daily				Organizational				
	B1	D2	A3	W4	M5	Q6			
1	X	-----	-----	-----	-----	-----	Launchers-----	Check for damage or malfunctions, which would cause stoppages during firing. Assure that the bore is dry and free of obstruction. Check for dents, tension of barrel latch spring and condition of painted surfaces. Clean. Check for operation of "LOAD" and "FIRE" lever Check for powder fouling and/or corrosion of contact point. Inspect latch for retentive qualities. Check for broken or loose electrical wires. Oil assembly as required to assure proper functioning. (See fig. 3-1.)	
2	X	-----	-----	-----	-----	-----	Barrel assemblies-----		
-----	X	-----	-----	-----	X	-----	-----		
3	X	-----	X	-----	-----	-----	Contacto latch assembly----		
-----	X	-----	-----	-----	X	-----	-----		

4	X	---	---	---	X	-----	Firing mechanism assembly.	Check for proper operation of safety. Actuate trigger and listen for a distinct click. This will assure operation of magneto.
-----	-----	-----	-----	-----	X	-----	-----	Check grips for cracks and/or unserviceability. Check safety for correct functioning. Check for loose or damaged electrical wire.
5	X	---	---	---	X	-----	Reflecting sight group-----	Check for operation. Make certain sight is cleaned thoroughly.

1B-Before operation.
2D-During operation.

3A-After operation.
4W-Weekly.

5M-Monthly.
6Q-Quarterly.

Section IV. TROUBLESHOOTING

3-7. General

Troubleshooting (table 3-2) contains information for operator and organizational maintenance and serves as an aid to personnel to detect malfunctions, their probable causes and the corrective action to follow.

Table 3-2. Troubleshooting

Malfunction	Probable cause	Corrective action
Failure to couple	Cracked or damaged screw. Bur on screw -----	Evacuate to direct support maintenance. Evacuate to direct support maintenance.
Failure to lock in coupled position.	Broken spring -----	Evacuate to direct support maintenance.
Failure of barrel latch to hold.	Broken barrel latch spring.	Evacuate to direct support maintenance.
Failure of hook and eye to secure barrels.	Deformed part -----	Evacuate to direct support maintenance.
Failure to lock -----	Weak or broken contactor latch spring.	Evacuate to direct support maintenance.
Failure to fire -----	Weak electrical output. Improper contact of blade. Broken contact spring.	Evacuate to direct support maintenance. Evacuate to direct support maintenance. Evacuate to direct support maintenance.
Failure to trigger -----	Deteriorated insulator sleeve. Obstruction in trigger slot.	Evacuate to direct support maintenance. Remove obstruction from trigger slot.
Failure of safety -----	Defective shunt----- Broken trigger lug.	Evacuate to direct support maintenance. Evacuate to direct support maintenance.
Failure of lock of sight assembly.	Broken spring-----	Evacuate to direct support maintenance.
Failure of lens cover to open or close.	Broken spring-----	Evacuate to direct support maintenance.
Failure to fire accurately.	Defective sight assembly.	Evacuate to direct support maintenance.

Section V. MAINTENANCE PROCEDURES

3-8. General

This section provides repair instructions for all items designated by the MAC (app. C) for operator and organizational maintenance.

3-9. Removal/Installation of Barrels

Note. White arrows indicate removal and black arrows installation.

Refer to figure 2-4.

3-10. Disassembly

a. The cover of the contactor latch assembly may be removed, for lubrication, by removing the screws and washers as shown in figure 3-1.

b. Further disassembly of the launcher is not authorized.

3-11. Cleaning and Inspection

a. Cleaning. Refer to paragraph 3-3.

b. Inspection.

(1) Visually inspect all parts for damage, wear, burs, rust, foreign matter in recesses, deformation and free action with mating parts.

(2) Inspect the barrel assemblies for dents, scratches and deformation, check tension of barrel latch spring.

(3) Inspect the contactor latch assembly for powder fouling or corrosion. Inspect for broken or loose wires and for worn or corroded latch springs. Also, check contact brackets for cracks, wear, and deformation.

(4) Inspect the firing mechanism assembly for cracked grips, functioning of safety and for loose or damaged electrical wires.

CHAPTER 4 AMMUNITION

4-1. General

Ammunition for the 3.5-Inch Rocket Launchers M20A1 and M29A1B1 is issued in the form of complete rounds of fixed ammunition. The term "fixed", used in conjunction with ammunition, signifies that the propelling charge is fixed (not adjustable) and that the round is loaded into the launcher as a unit. The complete round consists of a rocket lead, a fuse, and a rocket motor which contains the propellant and igniter. A tail assembly is rigidly attached to the rear of the motor. The fuse body, threaded at both ends, serves also as a coupling for the rocket head and motor.

4-2. Classification

Ammunition for these rocket launchers consists of the following types which are classified according to the rocket head as high-explosive antitank (HE, AT), smoke (WP), and practice.

a. The high-explosive antitank (HE, AT) rocket (fig. 4-1) which contains a high-explosive shaped charge, is intended for penetration of armored targets.

b. The smoke (WP) rocket (fig. 4-2) which is the same size and shape as the (HE, AT) rocket, contains a white phosphorous smoke filler and is intended to produce screening or signaling smoke.

c. The practice rocket (fig. 4-3) which simulates the service rockets, has an inert head and is intended for target practice purposes.

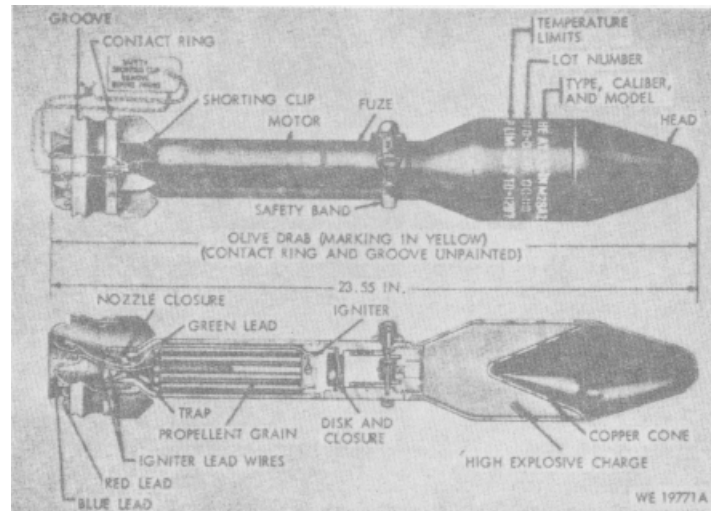

Figure 4-1. 3.5-Inch High Explosive Rocket, HE, AT, M28A2.

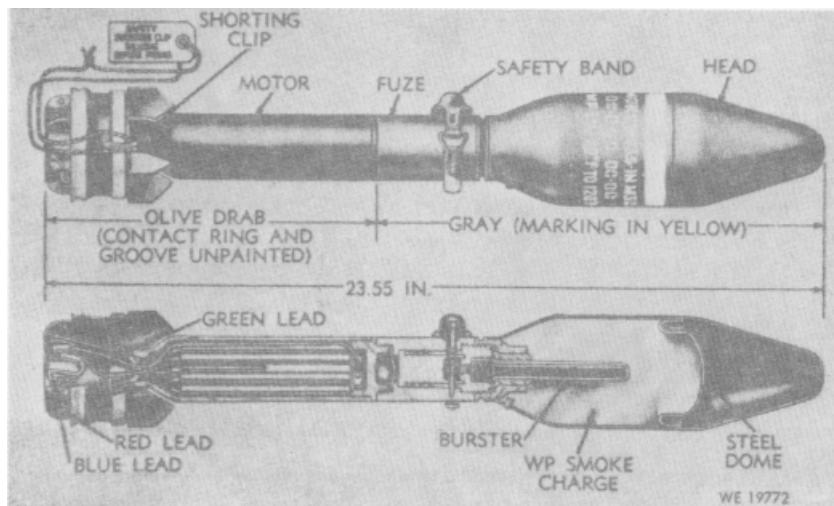

Figure 4-2. 3.5-Inch Smoke Rocket, WP, M30 (T127E3).

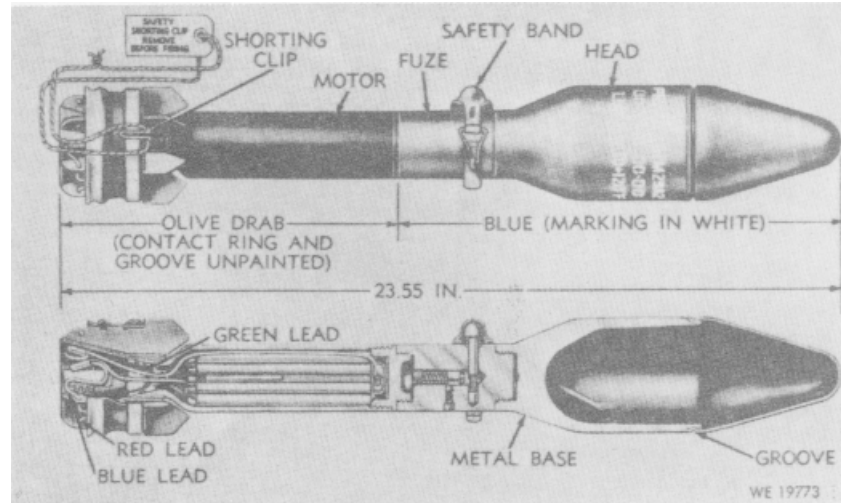

Figure 4-3. 3.5-Inch Practice Rocket, M29A2.

4-3. Identification

a. *General.* Ammunition and ammunition components are completely identified by painting and marking (including an ammunition lot number) on the ammunition items and on all original packing containers.

b. *Model.* To identify a particular design, a model designation is assigned at the time the item is classified as an adopted type. This model designation becomes an essential part of the nomenclature and is included in the marking on the item. The present system of model designation for a standard item consists of the letter "M" followed by an Arabic numeral; for example "M28". Modifications are indicated by adding the letter "A" and the appropriate Arabic numeral. Thus, "M28A1" indicates the first modification of an item for which the original designation was "M28". Wherever a "B" suffix appears in a model designation, it indicates an item of alternative (or substitute) design, material, or manufacture. Development items are indicated by letter "T" of "XM" and an Arabic numeral; for example, "T127". Modifications are indicated by adding the letter "E" and the appropriate Arabic numeral. Thus, "T1927E3" indicates the third modification of a development item for which the original designation was "T127".

c. *Ammunition Lot Number.* When ammunition is manufactured, an ammunition lot number is assigned in accordance with pertinent specifications. This lot number is stamped or marked on every loaded complete round and on all packing containers. It is required for all purposes of record, including reports on condition, functioning, or accidents in which the ammunition may be involved. In any one lot of ammunition, the components used in the assembly are manufactured under as nearly identical conditions as practicable. To obtain the greatest accuracy when firing, successive rounds should consist of one ammunition lot whenever practicable.

d. *Painting.* Rocket heads are painted primarily to prevent rust and to provide, by the color, a ready means of identification as to type.

Lusterless paint is used to meet requirements for camouflage. Rocket motors of old manufacture are painted olive drab.

	<i>Old Manufacture</i>	
<i>Type of Rocket Head</i>		<i>Color, and Marking</i>
High-explosive antitank -----		Olive drab; marking in yellow.
Chemical (WP) -----		Gray; one band and marking in yellow.
Practice -----		Blue; marking in white.

e. *Marking.* Standard markings are stenciled on the rocket in the appropriate color in accordance with the basic color scheme described in d above. These markings include the following:

(1) *On the rocket head (stenciled, unless otherwise indicated).*

- (a) Type, caliber, and model of rocket.
- (b) Ammunition lot number and loader's initials.
- (c) Month and year loaded.
- (d) Temperature limitations within which it is safe to fire the rocket.

(e) The metal parts lot number, date (month and year) manufactured, caliber and model designation is stamped in the metal.

(2) *On the fuse (stamped in the metal).*

- (a) Loader's lot number, date (month and year) loaded.
- (b) Type and model of fuse.

(3) *On the motor (stenciled).* Metal parts lot number, date (month and year) manufactured.

f. *Specific Identification.* The rockets may be identified by the conventional ogival nose, and removable safety band which is fitted around the base detonating fuse located between the head and motor.

4-4. Care, Handling, and Preservation

***Warning.* Explosive ammunition or components containing explosives must be handled with appropriate care at all times. The explosive elements in igniters and fuzes are particularly sensitive to undue shock and high temperature. Boxes containing ammunition should not be dropped, tumbled, or dragged.**

a. Ammunition is packed to withstand conditions ordinarily encountered in the field. Care must be observed to keep packings from becoming broken or damaged. All broken packings must be repaired immediately and careful attention given to the transfer of all markings to the new parts.

b. When it is necessary to leave ammunition in the open, raise it on dunnage at least 6 inches from the ground and cover it with a double thickness of paulins, leaving enough space for the circulation of air. Where practicable, dunnage strips should be placed under each layer of boxes and other ammunition components. Suitable trenches should be dug to prevent water from running under the pile.

c. Since explosives are adversely affected by moisture and high temperature, due consideration should be given to the following:

(1) Do not break the moisture-resistant seals until ammunition is to be used. Ammunition removed from airtight containers, particularly in damp climates, is apt to corrode, thereby rendering the ammunition unserviceable.

(2) Protect ammunition from high temperature and direct rays of the sun. Rockets should never be stored where the temperature may exceed 120°F. More uniform firing is obtained if the rounds are at the same temperature.

(3) Do not attempt to disassemble any rocket.

(4) Rockets should be free of sand, mud, moisture, frost, snow, ice, grease, or any foreign matter. If rounds become dirty or wet, they should be wiped off at once with a clean, dry, wiping cloth.

(5) In handling and storage, rockets should at all times be kept pointed in the direction that would result in the least damage should the propellant be accidentally ignited.

(6) Rockets prepared for firing, but not fired, will be returned to their original condition and packings and will be appropriately marked. Such ammunition will be used first in subsequent firings in order that stocks of opened packages may be kept at a minimum.

(7) Do not handle duds because their fuzes may be armed; duds are extremely dangerous.

They will not be moved or touched but will be destroyed in place in accordance with TM 91300-206.

(8) Do not disassemble any fuzes.

4-5. Authorized Rounds

Ammunition authorized for use in the 3.5-Inch Rocket Launchers M20A1 and M20A1B1 is listed in table 4-1. Standard nomenclature, which is used in the listing, completely identifies the ammunition except for ammunition lot number.

a. *Rocket Head.*

(1) *HE, AT Rocket M28-1A2.* The head of this rocket consists of a thin gage steel body, cylindrical in shape and tapered at the rear. The cylindrical portion is 3.5 inches in diameter; the rear of the tapered portion, approximately 2 inches. The body contains a copper cone, whose apex is to the rear, which acts to shape the high-explosive charge of approximately 1.88 pounds of Composition B. The penetration effect is derived from the shaped charge. The forward end of the body is closed by a tapered thin gage metal ogive. The head is threaded internally at the rear to receive the fuze.

(2) *Practice Rocket M29A2.* The head of this practice rocket is similar in external contour to the head of the HE, AT Rocket M28A2, except for a circumferential groove in the head at the juncture of the lead body and ogive due to the crimp by which the ogive and body are secured. The head, which is hollow, is threaded internally at the rear to receive a dummy fuze. An earlier manufacturing alternative is identical in contour with the head of the HE, AT Rocket M28A2, except for the lack of the crimping groove, consisting of the metal parts of the service head inert loaded with plaster of paris.

(3) *WP Smoke Rocket T127E2 and M30 (T127E3).* The head of these rockets is similar in external contour to the head of the HE, AT rocket M28A2. The head is internally threaded at the rear end and contains a 2.33-pound charge of white phosphorus. At the rear it

Table 4-1. Authorized Ammunition

Standard nomenclature	Complete round		Rocket head		Fuze--Standard action nomenclature
	length (in)	Weight (lb)	Length (in)	Weight (lb)	
ROCKET, HIGH EXPLOSIVE, 3.5-INCH: AT M28A2.	23.55	9.00	10.58	4.54	FUZE, ROCKET, PI-BD: M404A2 or M404A1.
ROCKET, PRACTICE 3.5-INCH: M29A2---	23.55	8.96	10.58	4.65	FUZE, ROCKET, INERT DUMMY: M405.
ROCKET, SMOKE, 3.5-INCH: WP, M30 (T127E3 or T127E2).	23.55	8.96	10.58	4.47	FUZE, ROCKET, PI-BD: M404A2 or M404A1.

has a union internally threaded to receive the fuze, the burster casing M8 is press fitted into the union, and the steel body fitted over it. The steel ogive and the internal steel dome, which close the forward end of the filler cavity, are attached to the body.

b. *Motor Assembly--Pockets M28A2, M29A2, T127E2 and M30 (T127E3).*

(1) *Description.* The rocket motor assembly consists of the motor body, tail assembly, shorting clip assembly, nozzle closure, propelling charge, igniter M20 and M20A1, trap and spacer assembly, and disk and closure assembly. The tail assembly is press fitted over the knurled rear portion of the motor body. The motor body is a steel tube threaded internally at the forward end to receive the disk and closure assembly, constricted to a nozzle internally at the rear and tapered to the knurled surface externally at the rear. The motor body contains the trap and spacer assembly, propelling charge, and igniter. The motor is sealed at the rear by a plastic nozzle closure and at the forward end by the disk and closure assembly. The trap and spacer assembly consists of the disk-like trap to which the spacer blades are fastened and is positioned in the motor lengthwise so that the blades divide the motor chamber into four compartments. The trap is positioned in the rear of the motor to prevent loss of propellant during burning. The motor assembly is threaded externally at the forward end to engage the fuze.

(2) *Tail assembly.* The tail assembly consists of a cone-shaped aluminum-alloy nozzle extension to which three double bladed fins are crimped or spot welded and three concentric rings are mounted over the fins. The three rings are the grooved support ring, plastic insulator ring, and contact ring assembly (outermost). The rings are held on the fins by rivets which also serve to connect the igniter lead wires to the support ring and contact ring.

(3) *Propelling charge.* The propelling charge consists of 12 nonperforated cylindrical extruded grains of solvent propellant M7. Each

grain is 5 inches long, approximately $\frac{3}{8}$ inch in diameter and weighs 0.03 pound. The propellant grains are positioned lengthwise, three in each of the four compartments formed by the spacer blades. Since the rate of burning increases with the initial temperature, it is important not to fire rockets at temperatures beyond the limits marked on each rocket. Firing at temperatures below the minimum (-20°F.) will give erratic ranges and excessive back blast of propellant particles; firing at temperatures above the maximum (+120°) may cause dangerous pressures to build up within the motor.

(4) *Igniter.* The igniter M20 or M20A1 which consists of a short cylindrical plastic case containing a 10-gram black powder charge and an electric squib M1A1 or M2 is assembled in the forward end of the motor in the recessed portion of the motor closure. The lead wires of the electric squib, running parallel to the propellant grains, pass from the igniter through the nozzle closure and the expansion cone where one lead wire is connected to the ground lead cable (green) and the other to the live cable (red).

(5) *Electric circuit.* The electrical circuit for these rockets is comprised of the igniter, the terminal lead assembly (ground), the terminal lead assembly (live and auxiliary), the support ring, the contact ring, and the shorting clip. The contact ring is connected to the terminal lead assembly (red live lead) which is connected to one igniter lead wire. The launcher makes ground contact with the groove of the support ring. The ground lead cable (green) is connected to the support ring and also to the other igniter lead wire. The shorting clip spring is assembled over the edge of the contact ring and support ring providing a direct connection between the support ring (ground contact) and contact ring (live contact) and thus "short circuiting" the igniter. The rocket cannot be fired while the shorting clip is in place.

c. *Fuzes.* For description of fuzes used with the 3.5-inch rocket ammunition refer to paragraph 4-6.

4-6. Fuzes

a. *General.* A fuze is a device used with ammunition to cause it to function at the time and under the circumstances desired.

b. *Classification.* Rocket fuzes are classified according to location in the head as PD (point detonating) or BD (base detonating). Fuzes are classified according to functioning as time, proximity, PI (point initiating), or impact. Fuzes are classified also according to a combination of location and functioning as PI BD (point initiating base detonating). Time fuzes function a preselected number of seconds after the round is fired. Impact fuzes function upon impact with super-quick, non-delay, or delay action. In the case of super-quick action, the projectile functions practically instantaneously on impact, initiated by a firing pin driven into a detonator. Nondelay action occurs in impact fuzes initiated by inertia-driven firing pins or detonators, being only slightly slower than super-quick action. In delay action fuzes, the projectile functions a fixed time after impact to permit penetration of the target before the projectile explodes. Arming may be accomplished by mechanical means utilizing gear trains, air stream (air arming), spring action, centrifugal force or inertia, gas pressure (pressure arming), or a combination thereof.

c. *Fuze, Rocket, BD-M404 Series.*

(1) *Description.* This fuze is of the simple inertia (setback arming) type which functions with non-delay action upon impact or graze. The fuze mechanism consists of an activating plunger, a setback spring, a setback sleeve, a firing pin assembly, a detent and detent spring, an ejection pin and an ejection spring. The safety band restrains outward movement of the spring loaded ejection pin, which passes through the fuze body, preventing movement of the internal parts and thus preventing accidental functioning during shipping and handling. When the rocket is loaded in the launcher, the ejection pin is depressed until coming in contact with the bore of the launcher. After firing, the setback forces act upon the setback sleeve to retract it toward the rear of

the fuze. A pin holds the sleeve in the retracted position. Upon emergence of the rocket from the launcher, the ejection pin is ejected clear of the fuze by a spring, and the fuze becomes armed. Upon impact, the activating plunger moves forward activating the lever action of the firing pin. This drives the firing pin into the detonator and explodes the rocket.

(2) *Preparation for firing.* No preparation of the fuze for firing is required other than removal of the safety band.

d. *Fuze, Rocket, Dummy—M405.* The dummy fuze M405 is an inert fuze similar in appearance to the BD fuze NM404 series described in paragraph c, above. It simulates the handling and pin ejection of BD fuze M404 series with a double-locking, bore-riding, round ejection pin and a safety band which is removed prior to firing.

4-7. Preparation for Firing

a. *Preparation of Rockets-Rocket. M28A2, M29A2, M30 or T127E2.* After rockets are removed from their packings, they are prepared for firing as follows:

Warning. Examine the launcher to make sure that the safety switch of the trigger grip on the electrical firing mechanism is in a "SAFE" position (fig. 2-1).

(1) All 3.5-Inch Rockets M28A2, WP Smoke Rockets T127E2 and WP Smoke Rockets M30 (T127E3) should be examined for loose heads. Examine for a discernible 360° gap between the head and the fuze.

Warning. Any round which has a discernible 360° gap between the head and the fuze is not to be fired. Any rocket evidencing this condition will be returned to segregated ammunition storage in a properly marked container indicating the condition.

(2) Check rocket for loose nozzle closure by gently pulling the red and green ignition lead wires that pass through the closure. Any movement of the closure indicates failure of bond. A loose closure

may result in the rocket falling short or "chuffing" (intermittent burning with a puffing noise) when fired.

(3) Remove tile shorting clip from the contact ring assembly of the rocket.

(4) Move the control handle of the launcher forward to the "LOAD" position. Remove the safety hand from the fuze, and carefully push the rocket into the launcher tube until the detent engages the continuous groove in the support ring.

Note 1. Two spring-loaded stops will properly position the rocket inside the launcher.

Note 2. Prior to loading the rocket into the launcher, test the ejection pin of the fuze to insure that it is free from binding. This is done by depressing the pin the fingers and releasing it. If the ejection pin binds while being depressed or twisted. reject the rocket and report the condition to the Ammunition Officer.

Caution. When loading the rocket into the launcher, depress the ejection pin with the fingers until the pin is in the bore of the launcher. Make sure that the pin is pointed downward or to the side. Failure to hold the ejection pin depressed while loading the rocket may result in the pin coming in contact with the breech end of the launcher tube and thereby becoming bent. Failure to point the ejection pin downward or to the side may result in the pin striking the position stops and becoming bent. Observance of these procedures gives greater assurance of proper functioning of the rocket.

(5) When ready to fire move the, handle forward to the "FIRE" position.

b. Rocket. Prepared or Firing but not Fired-Rockets M28A2, M29A2, M30, or T127E.

(1) Before unloading the launcher, make sure that the safety switch of the trigger grip on the electrical firing mechanism is in a "SAFE" position.

(2) Move the control handle forward to the "LOAD" position. Raise the detent spring assembly, and carefully withdraw the rocket from the launcher tube. *Install the (safety band over the ejection pin and replace the shorting clip.*

(3) Rockets prepared for firing, but not fired, will be returned to their original condition and packings and will be appropriately marked. Such ammunition will be used first in subsequent firings in order that stocks of opened packings may be kept at a minimum.

4-8. Precautions in Firing

a. The following precautions should be closely observed in order to prevent injury to personnel and damage to materiel.

(1) Rockets should be free of sand, mud, moisture, frost, snow, ice, grease, or any foreign matter. If rockets become dirty or wet, they should be wiped off at once with a clean, dry wiping cloth.

(2) Care should be exercised in firing through a screen of brush or trees. Impact with a twig or branch may deflect the rocket or cause it to detonate.

(3) Do not drop the muzzle of the launcher immediately after firing, because the rocket may strike the foreground and cause serious injury to personnel.

(4) In firing rockets, consideration should be given to the blast of flame to the rear and the rearward flight of fragments of nozzle closures and igniter wires. If practicable, flammable material, such as dry vegetation, should be cleared from the blast area to the rear of the launcher. Personnel and ammunition should be clear of the rear danger area unless protected by adequate shelter. Refer to paragraph 2-9.

(5) Do not fire rockets at temperatures below -20°F . or above $+120^{\circ}\text{F}$. These temperature limits are marked on the rocket and are specified as the safe temperature limits.

(6) Do not fire rockets with damaged fins or motors. Damaged motors may cause dangerous pressures. Damaged fins will cause erratic flight.

(7) Be careful when loading rockets into the launcher to prevent damage to the fins of the tail assembly.

(8) Misfires will be handled in accordance with paragraph 2-10.

(9) Do not jar a loaded launcher.

(10) The rocket must be destroyed as soon as practical if the ejection pin is not in place in accordance with T-M 9-1300-206.

(11) When loading the rocket into the launcher, depress the ejection pin with the fingers until the pin is in the base of the launcher and make certain that the pin is pointed downward or to the side. Failure to hold the ejection pin depressed while loading the rocket may result in the pin coming in contact with the breech end of the launcher tube and thereby becoming bent. Failure to point the ejection pin downward or to the side may result in the pin striking the position stops and becoming bent. Observance of these procedures gives greater assurance of proper functioning of the rockets.

(12) Observe the **Warning** contained in paragraph 2-9 relative to protection of the eyes and/or face and hands.

b. The following additional precautions will be observed in firing rockets in freezing weather.

(1) *General.* Rockets will function normally at any temperature between the temperature limits marked thereon. However, there are certain precautions which should be observed to insure more reliable functioning when the atmospheric temperature is below 32°F., particularly during rainstorms, snowstorms, or in an atmosphere sufficiently humid to cause icing or frost. When rockets are subjected to temperature fluctuation, which may loosen the nozzle closure, moisture may enter and subsequently form ice or frost within the motor.

(2) *Protect the fuze cavity against the entrance of moisture.* The safety band, which is around the fuze, depresses the ejection pin of the fuze M404 series and seals the fuze against the entrance of moisture. When the band is removed preparatory to firing, moisture, if present, can enter the fuze cavity. Under these conditions, if considerable time elapses between removal of safety band and firing, moisture may have entered the fuze cavity and frozen. This might

prevent functioning of the fuze at the target, due to the formation of ice or frost within the fuze. Hence, it is important that the safety band be removed only just before firing and that the rocket be kept dry.

(3) *Prevent accumulation of ice or frost on the rocket.*

(a) *Avoid freezing of rocket to the launcher.* The 3.5-inch rocket develops a powerful thrust when fired. If, after loading, the rocket freezes to the launcher and then is fired, the launcher might be wrenched from the shooter's grasp and the launcher might be hurled forward and possibly cause injuries and damage.

(b) *Insure accuracy of flight.* Accumulation of ice on the rocket, particularly in such quantities as would appreciably affect its weight, balance, or flow of air through the fin, would have an adverse effect on accuracy of sight and range.

(4) *Face and hand protection.* Observe the **Warning** contained in paragraph 2-9 relative to face and hand protection.

(5) *Check for loose nozzle closures to prevent a "short range" of a "chuffing" rocket.* Wide and frequent temperature fluctuations, especially repeated fluctuations at temperatures below 0°F., may cause a failure of the bond between the nozzle closure and the nozzle of the rocket. This nozzle closure is of plastic material and is cemented to the nozzle by a rubber-base adhesive. The security of the closure can be checked before firing, by grasping and gently pulling the ignition led wires which pass through the closure or by visual inspection. A loose closure may result in the rocket falling short or "chuffing" (intermittent burning with a puffing noise) when fired. Either a short or chuffing rocket creates a hazard. A chuffing rocket may fall to the ground, a short distance from the rocket launcher, smolder, and then resume burning and be propelled in an unpredictable direction. A loose nozzle closure would also permit the entrance of moisture into the motor where it might freeze or wet the propellant and igniter causing a "misfire" or "hangfire".

Warning. Rockets with loose nozzle closure should not be fired, especially if there is evidence of moisture, ice, or frost in the motor.

4-9. Packing and Marking

a. Packing. The 3.5-inch rocket ammunition is packed as follows: one rocket in either a fiber or a metal container, three containers (three rockets) per wooden box (fig. 4-4). The overall dimensions of the packing box are approximately $29\frac{1}{4} \times 13\frac{7}{8} \times 6\frac{5}{8}$. The total weight is approximately 54 pounds and the cubical displacement approximately 1.6 cubic feet.

b. Marking. Packages of ammunition are marked to provide a ready means of identification as to contents. The adhesive sealing strips on fiber containers are in the same color scheme as the ammunition item, in accordance with the basic color scheme. The metal containers are painted and stenciled in accordance with the basic color scheme. The packing boxes of 3.5-inch rocket ammunition are marked in black as follows:

- (1) ICC nomenclature.
- (2) Federal Stock Number and Department of Defense Identification Code.
- (3) Storage temperature limits.
- (4) End of box in which fuze or nose is pointed is marked "Nose End".
- (5) Ordnance insignia.
- (6) Gross weight.
- (7) Cubical displacement.
- (8) Month and year loaded.
- (9) Ammunition lot number.
- (10) Bursting charge, if applicable.
- (11) Caliber and weapon designation.
- (12) Descriptive nomenclature of packed item.
- (13) Color stripe, if applicable.

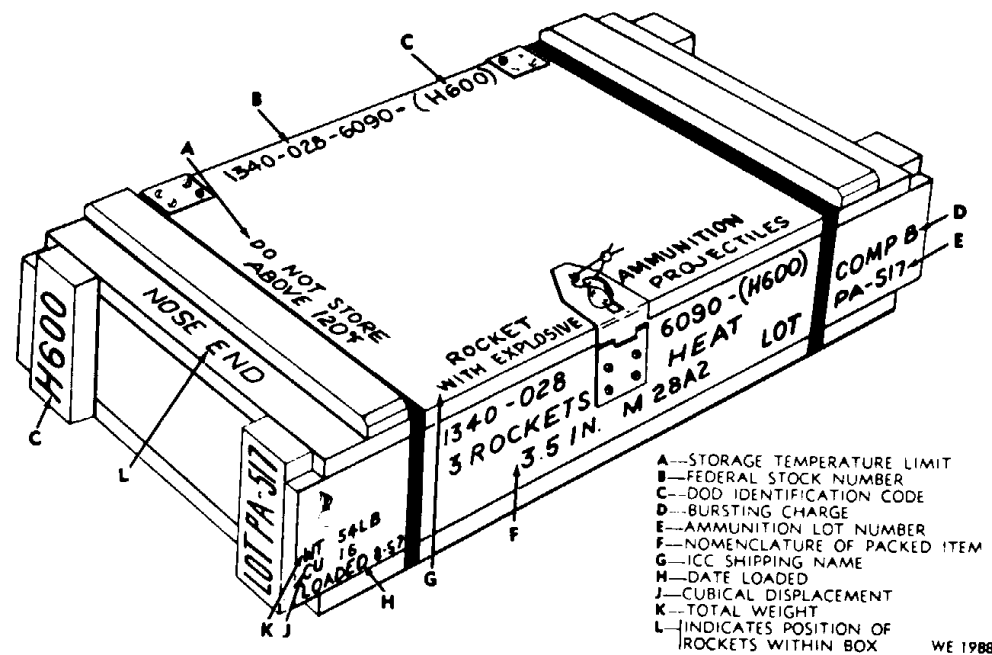

Figure 4-4. Packing box for 3.5-inch ammunition.

CHAPTER 5

DEMOLITION OF MATERIEL TO PREVENT ENEMY USE

5-1. General

a. Destruction of the Rocket Launchers M20A1 or M20A1B1, when subject to capture or abandonment in the combat zone, will be undertaken by the using army only, when, in the judgment of the unit commander concerned, such action is necessary in accordance with order of, or policy established by the Army commander.

b. The information which follows is for guidance only. Certain of the procedures outlined required the use of explosives and incendiary grenades which normally may not be authorized items of issue for the using organization. The issue of these and related materials, and the conditions under which destruction will be effected, are Command decisions in each case, according to the tactical situation. Of the several means of destruction, those most generally applicable are:

- Mechanical -----Requires axe, pick mattock, sledge, crowbar or similar implement.
- Burning-----Requires gasoline, oil, incendiary grenades, or other flammables.
- Demolition -----Requires suitable explosives or ammunition.
- Gunfire -----Includes artillery, machine guns, rifles using rifle grenades, and launchers using antitank rockets. Under some circumstances hand grenades may be used.

In general, mechanical destruction, followed by burning will usually be sufficient to render the rocket launcher useless. However, election of

the particular method of destruction requires imagination and resourcefulness in the utilization of the facilities at hand under the existing conditions. Time is usually critical.

c. If destruction to prevent enemy use is resorted to, the rocket launcher must be so badly damaged that it cannot be restored to a usable condition in the combat zone either by repair or cannibalization. Adequate destruction requires that all parts essential to the operation of the launcher be destroyed or damaged beyond repair.

However, when lack of time and personnel prevents destruction of all parts, priority is given to the destruction of those parts in the following order:

1. Firing mechanism.
2. Contactor latch assembly.
3. Reflecting sight group.
4. Front and rear barrel assemblies.

d. It is equally important, the same essential parts must be destroyed on all like materiel so that the enemy cannot construct one complete unit from several damaged ones. If destruction is directed, due consideration should be given to observance of appropriate safety precautions.

5-2. Destruction of Sighting and Fire Control Instruments and Equipment

All items of sighting and fire control instruments and equipment are costly, difficult to replace, yet, relatively light; hence, they should be conserved and evacuated whenever practicable. In the event evacuation is impracticable, the instruments and equipment will be destroyed completely. All optical elements and mountings will be smashed; ballistic data will be burned.

5-3. Destruction of the Launcher

a. *Method No. 1--by demolition.*

(1) Planning for simultaneous detonation prepare two demolition charges using a ½-pound **TNT** block or equivalent together

with the necessary detonating cord to make up each charge. Place the two charges as follows:

- (a) Place the *first* charge in or on the *front* barrel.
 - (b) Place the *second* charge on the *rear* barrel as close as possible to the electrical firing mechanism.
- (2) Connect the two charges for simultaneous detonation with detonating cord.
 - (3) Provide for dual priming to minimize the possibility of a misfire.
 - (4) Detonate the charges. For complete details on the use of demolition materials and methods of priming and detonating demolition charges, refer to FM 5-25. Training and careful planning are essential. Elapsed time: about 5 minutes.

b. Method No. 2--by burning.

- (1) *With combustible material.*
 - (a) Using an axe, sledge, or other heavy implement, smash the barrels, stock assembly, electrical firing mechanism, coupling lock, and contactor latch assembly.
 - (b) Place quantities of combustible material on and about the launcher. Pour gasoline or oil over the combustible material. Ignite and take cover. A very hot fire is required to render the launcher useless. Elapsed time: about 7 minutes.

Warning. Due consideration should be given to the highly flammable nature of gasoline and its vapor. Carelessness in its use may result in painful burns.

(2) *Alternate for above method.*

- (a) Insert four incendiary grenades end to end midway in the launcher tube.
- (b) Ignite the four grenades by means of a fifth one fitted with time blasting fuze of sufficient length so that it may be ignited from the breech or muzzle end.

Warning. Each roll of time blasting fuze must be tested shortly before use. The rate of burning will vary for the same or different roll under different atmospheric and/or climatic conditions, from a burning time of 30 seconds or less per foot to 45 seconds or more per foot.

(c) The metal from the incendiary grenades will fuze with the launcher tube and render it useless. Elapsed time: about 4 minutes.

c. *Method No. 3--by gunfire.* Destroy the rocket launcher by gunfire using adjacent artillery machine-guns, or rifles using rifle grenades. Fire on the launcher aiming at the tube and firing mechanism. Although one well-placed-direct hit may render the launcher temporarily useless, several hits may be required for complete destruction, unless an intense fire is started in which case the materiel may be considered destroyed. Elapsed time: about 3 minutes.

Warning. Firing of artillery at ranges of 500 yards or less should be from cover. Firing rifle grenades or antitank rockets should be from cover.

APPENDIX A REFERENCES

A-1. Publication Indexes

The following indexes should be consulted frequently for the latest changes or revision of references given in this appendix and for new publications relating to material covered in this manual.

Military Publications:

Index of Administrative Publications ----- DA Pam 310-1
Index of Army Films, Transparencies,
(GTA Charts, and Recordings)----- DA Pam 108-1
Index of Blank Forms ----- DA Pam 310-2
Index of Doctrinal, Training, and Organizational
Publications ----- DA Pam 310-3
Index of Modification Work Orders ----- DA Pam 310-7
Index of Supply Catalogs and Supply Manuals
(Excluding Types 7, 8 and 9) ----- DA Pam 310-6
Index of Technical Manuals, Technical
Bulletins, Supply Manuals, (Types 7, 8
and 9) Supply Bulletins, and Lubrication ---- DA Pam 310-4
Orders

A-2. Supply Catalogs

Ammunition and Explosives
(Identification List) ----- SC 1340/98 IL
Ammunition and Explosives
(Management Data List) ----- SC 1340/98 ML

A-3. Forms

The following form pertains to this material:

DA Form 2028, Recommended Changes to DA Publications.

A-4. Other Publications

The following explanatory publications pertain to this material:

a. General.

The Army Equipment Record

Procedures ----- TM 38-750

3.5-Inch Rocket Launcher ----- FM 23-32

b. Logistics.

Care, Handling, Preservation and

Destruction of Ammunition ----- TM 9-1300-206

Explosives and Demolitions ----- FM 5-25

c. Safety.

Field Protective Masks, M3, M4

and M9 Series and Protective

Mask Cannisters, M10A1, M11:

Serviceability Standards ----- SB 3-30-10

APPENDIX B

ORGANIZATIONAL MAINTENANCE REPAIR PARTS AND SPECIAL TOOLS LIST

Section I. INTRODUCTION

B-1. Scope

This appendix lists basic issue items, repair parts, special tools and equipment required for the performance of organizational maintenance of the rocket launchers.

B-2. General

The Basic Issue Items, Repair Parts, and Special Tools list is divided into the following sections:

- a. *Basic Issue Items List-Section II.* A list of items which accompany the rocket launchers and are required by the operator/crew for installation, operation, or maintenance.
- b. *Maintenance and Operating Supplies.* Not applicable.
- c. *Prescribed Load Allowance (PLA).* Not applicable.
- d. *Repair Parts.* Not applicable.
- e. *Special Tools, Test and Support Equipment--Section III.* A list of special tools, test and support equipment authorized for the performance of maintenance at organizational level.
- f. *Federal Stock Number and Reference Number Index.* Due to the number of items listed, this index is not applicable.

B-3. Explanation of Columns

The following provides an explanation of columns in the tabular lists in Sections II and III.

- a. Source, Maintenance, and Recoverability Codes (SMR).
 - (1) *Source Code.* Indicates the selection status and source for the listed item. Source codes are:

<i>Code</i>	<i>Explanation</i>
P -----	Repair parts which are stocked in or supplied from the GSA/DSA, or Army supply system, and authorized for use at indicated maintenance categories.
M-----	Repair parts which are not procured or stocked but are manufactured at indicated maintenance categories.
A -----	Assemblies which are not procured or stocked as such but are made up of two or more units, each of which carry individual FSNs and descriptions and are procured and stocked and can be assembled by units at indicated maintenance categories.
X -----	Parts and assemblies which are not procured or stocked; the mortality of which is normally below that of the applicable end item; and the failure of which should result in retirement of the end item from the supply system.
X1-----	Repair parts which are not procured or stocked, the requirements for which will be supplied by use of next higher assembly or component.
X2-----	Repair parts which are not stocked. The indicated maintenance category requiring such repair parts will attempt to obtain through cannibalization; if not obtainable through cannibalization such repair parts will be requisitioned with supporting justification through normal supply channels.
C -----	Repair parts authorized for local procurement. When not obtainable from local procurement, such repair parts will be requisitioned through normal supply channels with a supporting statement of nonavailability from local procurement.
G-----	Major assemblies that are procured with PEMA funds for initial issue only to be used as exchange assemblies at DSU and GSU level. These assemblies will not be stocked above DSU and GSU level or returned to Depot supply level.

(2) *Maintenance Code.* Indicates the lowest category of maintenance authorized to install the listed item. The maintenance level codes are:

<i>Code</i>	<i>Explanation</i>
C-----	Operator/crew.
O-----	Organizational.

(3) *Recoverability Code.* Indicates whether unserviceable items should be returned for recovery or salvage. Recoverability codes are:

<i>Code</i>	<i>Explanation</i>
R-----	Repair parts and assemblies which are economically repairable at DSU and GSU activities and are normally furnished by supply on an exchange basis.
T-----	High dollar value recoverable repair parts which are subject to special handling and are issued on an exchange basis. Such repair parts are normally repaired or overhauled at depot maintenance activities.
U-----	Repair parts specifically selected for salvage by reclamation units because of precious metal content, critical materials, high dollar value reusable casings, etc.
S-----	Repair parts and assemblies which are economically repairable at DSU and GSU activities and normally are furnished by supply on an exchange basis. However, when these items are determined to be uneconomically repairable by a GSU they will be evacuated to a depot for evaluation and analysis before final disposition.
No Code Indicated.	Parts will be considered expendable.

b. Federal Stock Number. Indicates the Federal stock number assigned to the item and will be used for requisitioning purposes.

c. Description. Indicates the Federal item name and any additional description of the item required. The abbreviation, w/e, when used as a part of the nomenclature, indicates the Federal stock number includes all armament, equipment, accessories, and repair parts issued with the item. A part number or other reference number is followed by the applicable five-digit Federal supply code for manufacturers in parentheses.

d. Unit of Measure (U/M). A two-character alphabetic abbreviation indicating the amount or quantity of the item upon which the allowances are based, e.g., ft, ea, pr, etc.

e. Quantity Incorporated in Unit. Indicates the quantity of repair parts in an assembly. A "V" appearing in this column in lieu of a

quantity indicates that a definite quantity cannot be indicated (e.g., shims, spacers, etc.).

f. Quantity Furnished with the Equipment. Indicates the quantity of an item furnished with the equipment (BILL only).

g. 15-Day Organizational Maintenance Allowances.

(1) The allowance columns are divided into four subcolumns. Indicated in each subcolumn opposite the first appearance of each item is the total quantity of items authorized for the number of equipments supported. Subsequent appearances of the same item will have the letters "REF" in the allowance columns. Items authorized for use as required but not for initial stockage are identified with an asterisk in the allowance column.

(2) The quantitative allowances for organizational level of maintenance represents one initial prescribed load for a 15-day period for the number of equipments supported. Units and organizations authorized additional prescribed loads will multiply the number of prescribed loads authorized by the quantity of repair parts reflected in the appropriate density column to obtain the total quantity of repair parts authorized.

(3) Organizational units providing maintenance for more than 100 of these equipments shall determine the total quantity of parts required by converting the equipment quantity to a decimal factor by placing a decimal point before the next to last digit of the number to indicate hundredths, and multiplying the decimal factor by the parts quantity authorized in the 51-100 allowance column. Example, authorized allowance for 51-100 equipments is 12; for 140 equipments multiply 12 by 1.40 or 16.80 rounded off to 17 parts required.

(4) Subsequent changes to allowances will be limited as follows: No change in the range of items is authorized. If additional items are considered necessary, recommendation should be forwarded to Commanding General, Headquarters, U.S. Army Weapons Command, ATTN: AMSWE-SMM-SA, Rock Island, Ill. 61201 for

exception or revision to the allowance list. Revisions to the range of items authorized will be made by Headquarters, U.S. Army Weapons Command based upon engineering experience, demand data, or TAERS information.

h. Illustration.

(1) *Figure Number.* Indicates the figure number of the illustration in which the item is shown.

(2) *Item Number.* Indicates the callout number used to reference the item in the illustration.

B-4. How To Locate Repair Parts

When Federal stock number or reference number is unknown:

a. First. Using the table of contents determine the functional group within which the repair part belongs. This is necessary because separate illustrations are prepared for functional groups and listings are divided into the same groups.

b. Second. Find the illustration covering the functional group to which the repair part belongs.

Note. Do not bypass this part of the procedure. Positive identification of the repair part is required.

c. Third. Identify the repair part on the illustration and note the illustration figure and item number of the repair part.

d. Fourth. Using the Repair Parts Listing, find the functional group to which the repair part belongs and locate the illustration figure and item number noted on the illustration.

B-5. Federal Supply Codes for Manufacturers

<i>Code</i>	<i>Explanation</i>
19204-----	Rock Island Arsenal, Rock Island, Ill.

Section II. BASIC ISSUE ITEMS LIST

(1) Source maint and recov code			(2) Federal stock No.	(3) Description	(4) Unit of meas	(5) Qty inc. in unit	(6) Qty furn. with equip.	(7) Illustration	
(a) Source	(b) Maint	(c) Recov						(a) Figure No.	(b) Item No.
				REPAIR PARTS: None authorized TOOLS AND EQUIPMENT					
P	C	-----	1005-654-4058	SLING, SMALL ARMS: M1, webbing 6544058 (19204)-----	Ea	-----	1	B-1	1
P	C	-----	4933-714-9835	WRENCH AND SCREWDRIVER COMBINATION: 7149835 (19024)-----	Ea	-----	1	B-1	2
				TECHNICAL MANUAL, TM 9-1055-201-12-----	Ea	-----	1	-----	-----

Section III. SPECIAL TOOLS AND EQUIPMENT FOR ORGANIZATIONAL MAINTENANCE

(1) Source maint and recov code			(2) Federal stock No.	(3) Description	(4) Unit of meas	(5) Qty inc. in unit	(6) 15 day organizational maint. allowance				(7) Illustration	
(a) Source	(b) Maint	(c) Recov					(a) 1-5	(b) 6-20	(c) 21-50	(d) 51-100	(a) Figure No.	(b) Item No.
P	C	-----	1005-654-4058	TOOLS AND EQUIPMENT AUTHORIZED FOR UNIT REPLACEMENT SLING, SMALL ARMS: M1, webbing 6544058 (19204)	Ea	-----	*	*	*	*	B-1	1
P	C	-----	4933-714-9835	WRENCH AND SCREWDRIVER COMBINATION: 7149835 (19204)-----	Ea	-----	*	*	*	*	B-1	2

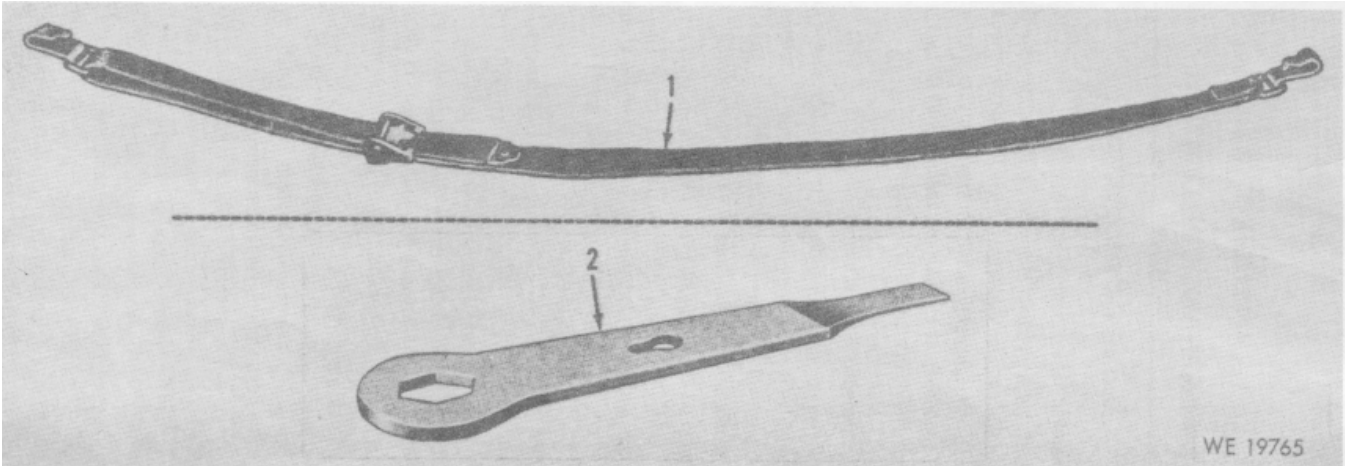

Figure B-1. Tools and equipment.

**APPENDIX C
MAINTENANCE ALLOCATION**

Section I. INTRODUCTION

C-1. General

The maintenance allocation chart indicates specific maintenance operations performed at proper maintenance levels. Deviation from maintenance operations allocated in the chart is authorized only upon approval of the commanding officer.

C-2. Maintenance Functions

The maintenance allocation chart designates overall responsibility for the maintenance function of an end item or assembly. Maintenance functions will be limited to and defined as follows:

INSPECT -----To determine serviceability of an item by comparing its physical, mechanical, and electrical characteristics with established standards.

TEST-----To verify serviceability and to detect electrical characteristics with established standards.

SERVICE -----To clean, preserve and lubricate.

ADJUST-----To rectify to the extent necessary to bring into proper operating range.

ALIGN -----To adjust specified variable elements of an item to bring to optimum performance.

CALIBRATE-----To determine the corrections to be made in the reading of instruments or test equipment used in precise measurement. Consists of the comparison of two instruments, one of which is a certified standard of known accuracy, to detect and adjust

any discrepancy in the accuracy of the instrument being compared with the certified standard.

INSTALL -----To set up for use in an operational environment such as an emplacement, site, or vehicle.

REPLACE -----To replace unserviceable items with serviceable assemblies, subassemblies or parts.

REPAIR -----To restore an item to serviceable condition. This includes, but is not limited to inspection, cleaning, preserving, adjusting, replacing, welding, riveting, and strengthening.

OVERHAUL-----To restore an item to a completely serviceable condition as prescribed by maintenance serviceability standards using the Inspect and Repair Only as Necessary (IROAN) technique.

REBUILD -----To restore an item to a standard as nearly as possible to original or new condition in appearance, performance, and life expectancy. This is accomplished through complete disassembly, of the item, inspection of all parts or components, repair or replacement of worn or unserviceable elements (items) using original manufacturing tolerances and specifications, and subsequent reassembly of the item.

C-3. Explanation of Format

Purpose and use of format are as follows:

a. Column a, Group Number. Lists group numbers, the purpose of which is to identify components and assemblies, subassemblies, and modules with the next higher assembly.

b. Column b, Component Assembly Nomenclature. Lists the noun names of components, assemblies, subassemblies, groups, and

modules on which maintenance is authorized.

c. Column c, Maintenance Functions. Lists the various categories of maintenance to be performed on the launchers.

d. Use of Codes. Explanation of the use of codes in maintenance column (c) is as follows:

<i>Code</i>	<i>Explanation</i>
C	Operator/crew.
O	Organizational Maintenance.
F	Direct Support Maintenance.
H	General Support Maintenance.
D	Depot Maintenance.

e. Column d, Tools and Equipment. This column will be used to specify those tools required to perform the designated function.

f. Column e, Remarks. Self-explanatory.

Note. Columns not utilized in this chart are considered not applicable to the launchers.

1-4. Tabulated Data

Section II. MAINTENANCE ALLOCATION CHART

Group no. (a)	Functional group (b)	Maintenance Function (c)											Tools and Equipment (d)	Remarks (e)
		In-spect	Test	Serv-ice	Ad-just	Align	Cali-brate	In-stal	Re-place	Re-pair	Over-haul	Re-build		
1	FRONT BARREL ASSEMBLY.	C	-----	C	-----	F	-----	C	F	F	D	-----		DS or higher to test electrical output of firing, mechanism.
2	STOCK-----	C	-----	C	-----		-----	F	F	F	D	-----		
3	CONTACTOR LATCH ASSEMBLY.	O	-----	O	F	-----	-----	F	F	F	D	-----		
4	FIRING MECHANISM GROUP	C	F	O	-----	-----	-----	F	-----	F	D	-----	Tester electrical output (1055-714-2554)	
5	REFLECTING SIGHT GROUP	C	-----	C	C	C	-----	F	-----	F	D	-----		
6	REAR BARREL ASSEMBLY.	C	-----	C	-----	-----	-----	F	-----	F	D	-----		

By Order of the Secretary of the Army:

W.C. WESTMORELAND,
General, United States Army
Chief of Staff

Official:
KENNETH G. WICKHAM,
Major General, United States Army
The Adjutant General

Distribution:

To be distributed in accordance with DA Form 1240 (qty rqr block No. 34), organizational maintenance requirements for Launcher, Rocket, 3.5incih, M20A1, M20A1B1.

☆ GPO : 1991 0 - 281-486 (43028)

RECOMMENDED CHANGES TO EQUIPMENT TECHNICAL PUBLICATIONS



THEN... JOT DOWN THE DOPE ABOUT IT ON THIS FORM, CAREFULLY TEAR IT OUT, FOLD IT, AND DROP IT IN THE MAIL!

SOMETHING WRONG

WITH THIS PUBLICATION?

FROM: (PRINT YOUR UNIT'S COMPLETE ADDRESS)

DATE SENT

PUBLICATION NUMBER

PUBLICATION DATE

PUBLICATION TITLE

BE EXACT... PIN-POINT WHERE IT IS				IN THIS SPACE TELL WHAT IS WRONG AND WHAT SHOULD BE DONE ABOUT IT:
PAGE NO	PARA-GRAPH	FIGURE NO	TABLE NO	

PRINTED NAME, GRADE OR TITLE, AND TELEPHONE NUMBER

SIGN HERE

TEAR ALONG PREPERATED LINE

DA FORM 2028-2
1 JUL 79

PREVIOUS EDITIONS ARE OBSOLETE.

P.S.—IF YOUR OUTFIT WANTS TO KNOW ABOUT YOUR RECOMMENDATION MAKE A CARBON COPY OF THIS AND GIVE IT TO YOUR HEADQUARTERS.

**TM 9-1055-201-12 LAUNCHER, ROCKET, 3.5-INCH M20A1 AND
M20A1B1--1968**

PIN : 026444-000